XV. Mathematics, Grade 10

Grade 10 Mathematics Test

The spring 2008 grade 10 MCAS Mathematics test was based on learning standards in the Massachusetts *Mathematics Curriculum Framework* (2000). The *Framework* identifies five major content strands listed below.

- Number Sense and Operations
- Patterns, Relations, and Algebra
- Geometry
- Measurement
- Data Analysis, Statistics, and Probability

The grades 9–10 learning standards for each of these strands appear on pages 72–75 of the *Mathematics Curriculum Framework*, which is available on the Department Web site at www.doe.mass.edu/frameworks/current.html.

In *Test Item Analysis Reports* and on the Subject Area Subscore pages of the *MCAS School Reports* and *District Reports*, Mathematics test results are reported under five MCAS reporting categories, which are identical to the five *Framework* content strands listed above.

Test Sessions

The MCAS grade 10 Mathematics test included two separate test sessions, which were administered on consecutive days. Each session included multiple-choice and open-response questions. Session 1 also included short-answer questions.

Reference Materials and Tools

Each student taking the grade 10 Mathematics test was provided with a grade 10 Mathematics Reference Sheet. A copy of the reference sheet follows the final question in this chapter.

During session 2, each student had sole access to a calculator with at least four functions and a square root key. Calculator use was not allowed during session 1.

The use of bilingual word-to-word dictionaries was allowed for current and former limited English proficient students only, during both Mathematics test sessions. No other reference tools or materials were allowed.

Cross-Reference Information

The table at the conclusion of this chapter indicates each item's reporting category and the *Framework* learning standard it assesses. The correct answers for multiple-choice and short-answer questions are also displayed in the table.

Mathematics

SESSION 1

You may use your reference sheet during this session.

You may **not** use a calculator during this session.



DIRECTIONS

This session contains fourteen multiple-choice questions, four short-answer questions, and three open-response questions. Mark your answers to these questions in the spaces provided in your Student Answer Booklet.

- 1 The table below shows a linear relationship between the values of x and y .

x	y
1	1
2	6
3	11
4	16

Based on the relationship in the table, what is the value of y when $x = 7$?

- A. 35
- B. 31
- C. 28
- D. 21

- 2 Which of the following is closest to the value of the expression below?

$$\sqrt{5^2 - 8}$$

- A. 1.4
- B. 2.2
- C. 4.1
- D. 8.5

- 3 Sharon took 24 nighttime photographs. The exposure times, in seconds, for her photographs are represented in the stem-and-leaf plot below.

Exposure Times (in seconds)

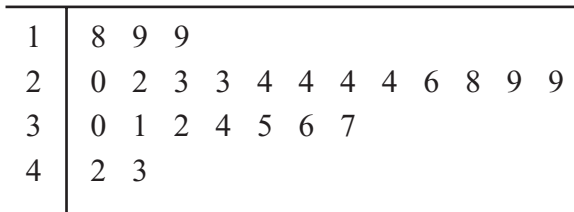

Key	
3 2	represents 32

What is the median exposure time for her photographs?

- A. 24 seconds
- B. 25 seconds
- C. 27 seconds
- D. 28 seconds

- 4 Which of the following is equivalent to the expression below?

$$100 \times 10^9$$

- A. 10^{10}
- B. 10^{11}
- C. 10^{12}
- D. 10^{18}

- 5 The first five numbers of a quadratic sequence are shown below.

$$4, 6, 11, 19, 30, \dots$$

What is the next number in the sequence?

- A. 44
- B. 43
- C. 42
- D. 41

- 6 A polygon and expressions representing its dimensions, in meters, are shown below.

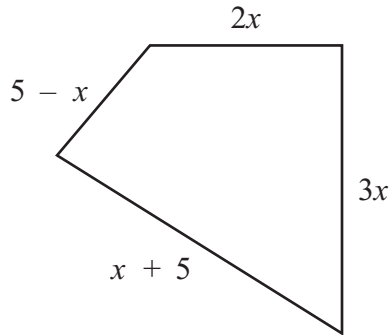

Which of the following represents the perimeter, in meters, of the polygon?

- A. $5x$
- B. $15x$
- C. $5x + 10$
- D. $7x + 10$

- 7 A square has an area of 75 square meters. Which of the following is closest to the length of a side of the square?

- A. 7.8 meters
- B. 8.2 meters
- C. 8.7 meters
- D. 9.1 meters

- 8 What are the solutions of the equation below?

$$2n(3n - 12) = 0$$

- A. 0 and 4
- B. 0 and 12
- C. 2 and 4
- D. 2 and 12

- 9 Shantel made the line plot below to show the numbers of points she and the other members of her team scored.

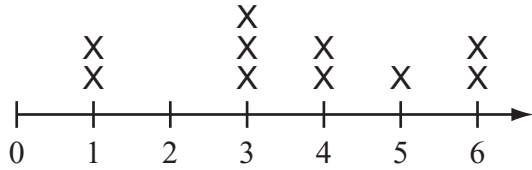

Numbers of Points Scored by Team Members

Exactly three players scored more points than Shantel. Based on the line plot, what is the number of points that Shantel scored?

- A. 2
- B. 3
- C. 4
- D. 5

- 10 What is the value of the expression below?

$$2(3 + 2)^2 - (-1)^2$$

- A. 18
- B. 22
- C. 49
- D. 51

- 11 Jessica wrote the equations below.

$$r = 27 \cdot n$$

$$s = 45 \cdot n$$

Which of the following expressions is equivalent to $s - r$?

- A. $(45 - 27)n$
- B. $45(27 - n)$
- C. $(45 - n)(27 - n)$
- D. $(45 - 27)(n - n)$

- 12 A line is shown on the coordinate grid below.

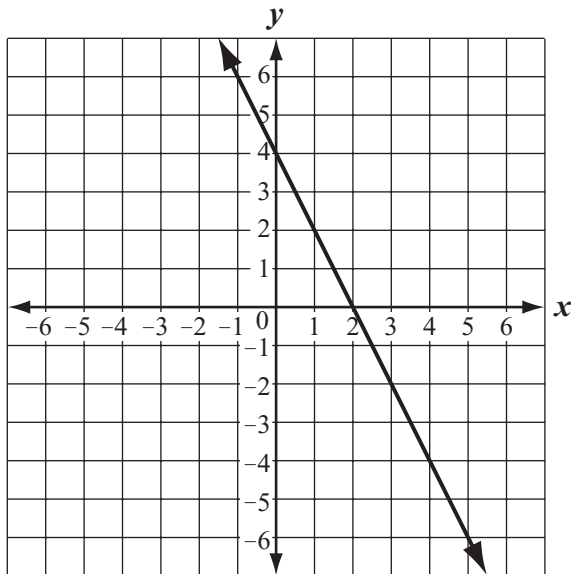

Which of the following best represents an equation of the line?

- A. $y = 2x + 2$
- B. $y = \frac{1}{2}x + 4$
- C. $y = -\frac{1}{2}x + 2$
- D. $y = -2x + 4$

- 13 What is the value of the expression below?

$$|-3 - 8| - |5 - (-2)|$$

- A. -14
- B. -2
- C. 4
- D. 8

- 14 The heights, in inches, of the members of a soccer team are listed below.

66, 61, 71, 62, 64, 70, 64, 63, 72, 68

After a new member joined the team, the median height of all the members was 66 inches.

Which of the following could be the height, in inches, of the new member?

- A. 68
- B. 65
- C. 64
- D. 61

Questions 15 and 16 are short-answer questions. Write your answers to these questions in the boxes provided in your Student Answer Booklet. Do not write your answers in this test booklet. You may do your figuring in the test booklet.

- 15 Laila is having shirts made with a logo printed on them to promote her band. The total cost consists of a one-time fee of \$75 to have the logo designed plus \$8 per shirt to print the logo.

Write an equation that Laila can use to determine the total cost, C , in dollars, to make x shirts.

- 16 Rectangle $KLMN$ and its dimensions are shown below. Point P lies on \overline{KL} .

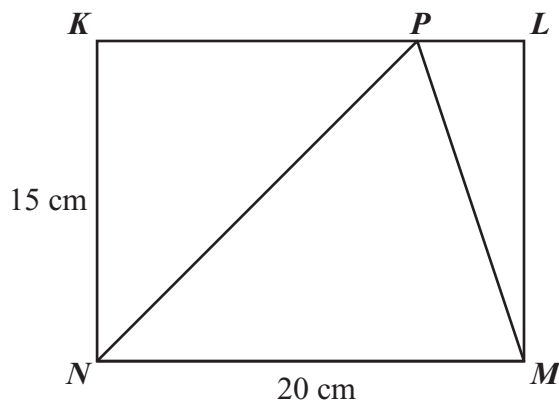

What is the area, in square centimeters, of $\triangle NPM$?

Question 17 is an open-response question.

- **BE SURE TO ANSWER AND LABEL ALL PARTS OF THE QUESTION.**
- **Show all your work (diagrams, tables, or computations) in your Student Answer Booklet.**
- **If you do the work in your head, explain in writing how you did the work.**

Write your answer to question 17 in the space provided in your Student Answer Booklet.

17 Line j is represented by the equation below.

$$\text{line } j: y = 2x + 4$$

- a. What is the slope of line j ? Show or explain how you got your answer.
- b. What is the slope of any line that is parallel to line j ? Explain your reasoning.
- c. Write an equation for the line, k , that is parallel to line j and passes through the point with coordinates $(3, 7)$. Show or explain how you got your answer.
- d. Write an equation for the line, h , that is **perpendicular** to line j and passes through the point with coordinates $(8, 10)$. Show or explain how you got your answer.

Questions 18 and 19 are short-answer questions. Write your answers to these questions in the boxes provided in your Student Answer Booklet. Do not write your answers in this test booklet. You may do your figuring in the test booklet.

- 18 Davis is on the high school track team. The table below shows the number of laps he ran around the school's track each day for 7 consecutive days.

Number of Laps Each Day

Day	Mon.	Tue.	Wed.	Thu.	Fri.	Sat.	Sun.
Number of Laps	8	11	7	9	10	11	12

What is the numerical difference between the median of the number of laps and the mode of the number of laps?

- 19 What is the value of the expression below?

$$3|2 - 6|$$

Questions 20 and 21 are open-response questions.

- **BE SURE TO ANSWER AND LABEL ALL PARTS OF EACH QUESTION.**
- **Show all your work (diagrams, tables, or computations) in your Student Answer Booklet.**
- **If you do the work in your head, explain in writing how you did the work.**

Write your answer to question 20 in the space provided in your Student Answer Booklet.

20 Glenn sells clothing at his store. He changes some prices each month.

- a. The original price of a jacket was \$30. Glenn increased the price by 10%. What is the new price of the jacket after the increase? Show or explain how you got your answer.
- b. The original price of a pair of sneakers was \$50.
- Glenn increased the price by 20% in April.
 - He then increased the price again by 20% in July.

What is the new price of the sneakers after both increases? Show or explain how you got your answer.

- c. The original price of a shirt was \$16.
- Glenn increased the price by 25% in April.
 - He then **decreased** the price by 30% in July.

Is the final price of the shirt the same as if the original price had been decreased by 5%? Show or explain how you got your answer.

- d. The original price of a coat was \$80. Glenn increased the price to \$100. By what percent did the price increase? Show or explain how you got your answer.

Write your answer to question 21 in the space provided in your Student Answer Booklet.

- 21 Jason launched a model rocket from the ground. The formula below can be used to determine the height of the rocket above the ground at any time during the rocket's flight.

$$h = 16t(7 - t)$$

In the formula, h and t are defined as follows:

- t = the time, in seconds, that has elapsed since the rocket was launched
- h = the height, in feet, of the rocket above the ground at time t

Use the formula to answer the following questions.

- a. What was the height, in feet, of the rocket 1 second after it was launched? Show your work.
- b. What was the height, in feet, of the rocket 6 seconds after it was launched? Show your work.
- c. The value of h was 0 when the rocket hit the ground. How many seconds after the rocket was launched did it hit the ground? Show your work.
- d. How many seconds after the rocket was launched was the height of the rocket 160 feet? Show your work.

Mathematics

SESSION 2

You may use your reference sheet during this session.

You may use a calculator during this session.



DIRECTIONS

This session contains eighteen multiple-choice questions and three open-response questions.

Mark your answers to these questions in the spaces provided in your Student Answer Booklet.

- 22 A parallelogram and its dimensions are shown below.

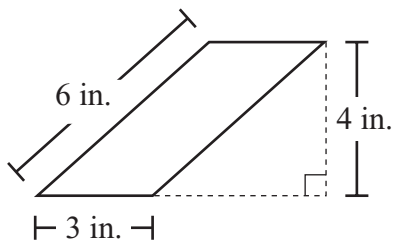

What is the area of the parallelogram?

- A. 12 sq. in.
- B. 13 sq. in.
- C. 18 sq. in.
- D. 24 sq. in.

- 23 In the diagram below, line l is parallel to line m , and line k intersects both lines.

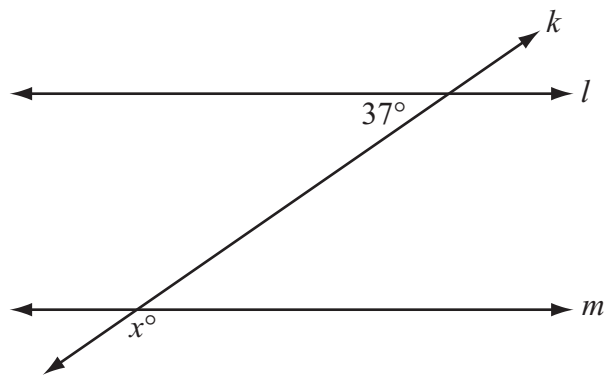

Based on the angle measure in the diagram, what is the value of x ?

- A. 37
- B. 53
- C. 127
- D. 143

24 In which of the following graphs does line k best represent a line with a slope of 0?

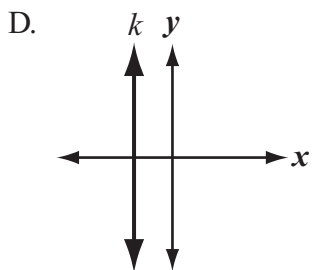
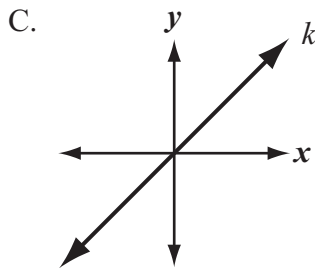
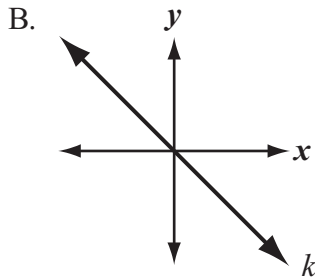
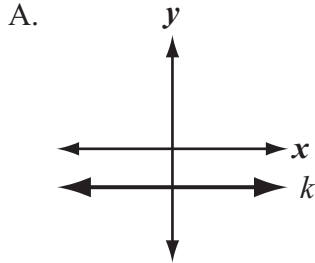

25 A large organization uses a phone tree to contact members.

- The director first contacts 3 members. This is the 1st set of calls.
- Each member who was contacted in the 1st set of calls then contacts 3 different members who were not previously contacted. This is the 2nd set of calls.
- The pattern continues with each member contacting 3 different members who were not previously contacted.

The table below shows the number of members contacted in each set of calls.

Phone Tree Calls

Set of Calls	Number of Members Contacted in This Set of Calls
1st	3
2nd	9
3rd	27
4th	81

If the pattern continues, what is the number of members who would be contacted in the 6th set of calls?

- A. 216
- B. 324
- C. 486
- D. 729

- 26 The rectangle below is a cross section of a three-dimensional object.



The rectangle could **not** be a cross section of which of the following objects?

- A. a cylinder
- B. a prism
- C. a cube
- D. a cone

- 27 An international basketball court has a region called the free-throw lane, shown as the shaded part in the diagram below.

- The free-throw lane is shaped like an isosceles trapezoid.
- A semicircle, shown as the unshaded part in the diagram, is attached to the shorter base of the trapezoid.
- The radius of the semicircle is 1.8 meters.

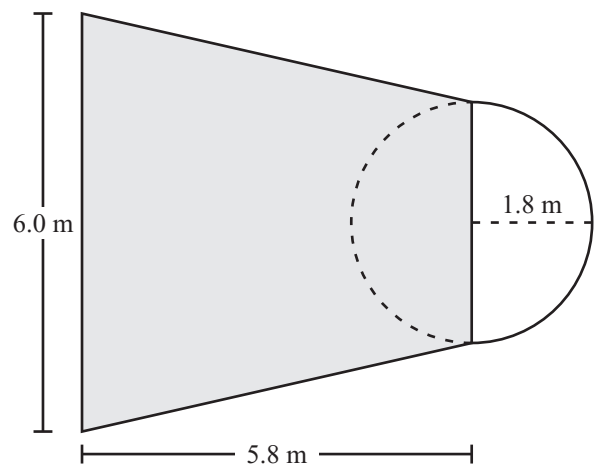

Based on the dimensions in the diagram, what is the area of the shaded free-throw lane?

- A. 22.62 square meters
- B. 27.84 square meters
- C. 34.80 square meters
- D. 55.68 square meters

- 28 The box-and-whisker plot below shows the distribution of the daily high temperatures, in degrees Fahrenheit, in the town of Clifton during the year 2004.

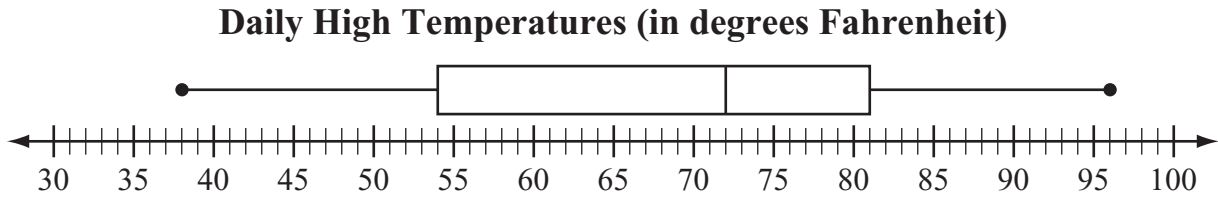

Based on the box-and-whisker plot, in which of the following intervals of temperatures is it most likely that exactly 50% of the daily high temperatures are located?

- A. 38°F to 54°F
 - B. 38°F to 81°F
 - C. 54°F to 72°F
 - D. 54°F to 81°F
-
- 29 For all nonzero values of x and y , which of the following expressions **must** equal 0?
- A. $x^0(y^0)$
 - B. $x^y - y^x$
 - C. $xy - yx$
 - D. $(x + y) + (x - y)$
- 30 The circumference of Sophie’s circular flower garden is 75 feet. Which of the following is closest to the **diameter** of her flower garden?
- A. 24 feet
 - B. 12 feet
 - C. 10 feet
 - D. 5 feet

Question 31 is an open-response question.

- **BE SURE TO ANSWER AND LABEL ALL PARTS OF THE QUESTION.**
- **Show all your work (diagrams, tables, or computations) in your Student Answer Booklet.**
- **If you do the work in your head, explain in writing how you did the work.**

Write your answer to question 31 in the space provided in your Student Answer Booklet.

31 The first six rows of a pattern are shown in the triangular array below.

Row 1				2					
Row 2				2	2				
Row 3				2	4	2			
Row 4				2	6	6	2		
Row 5				2	8	12	8	2	
Row 6				2	10	20	20	10	2
Row 7	?	?	?	?	?	?	?	?	

Each number in the array, other than 2, can be found by adding the two numbers in the preceding row that are diagonally above it. For example, $6 = 2 + 4$, as shown in the triangular array.

a. If the pattern continues, what are the seven numbers in Row 7? Show or explain how you got your answer.

Copy the table below into your Student Answer Booklet.

**Sum of the
Numbers in Each Row**

Row	Sum
1	
2	
3	
4	
5	
6	
7	

- b. Determine the sum of the numbers in each of the first seven rows of the pattern. Complete your table with these sums.
- c. If the pattern continues, what row will be the first row in which the sum of the numbers is greater than 600? Show or explain how you got your answer.
- d. Write a rule in terms of n that can be used to find the sum of the numbers in Row n . Show or explain how you got your answer.

Mark your answers to multiple-choice questions 32 through 40 in the spaces provided in your Student Answer Booklet. Do not write your answers in this test booklet. You may do your figuring in the test booklet.

32 Each of two different-sized boxes is in the shape of a right rectangular prism. The volume of the larger box is 4 times the volume of the smaller box. The dimensions of the smaller box are represented below.

- length: l
- width: w
- height: h

Which of the following could represent the dimensions of the larger box?

- A. $l, 4w, 4h$
- B. $2l, 2w, h$
- C. $2l, 2w, 4h$
- D. $4l, 4w, 4h$

33 On the spinner shown below, the sizes of the sections are as follows:

- Sections S and U are equal in size.
- Sections R and T are equal in size.
- The size of section S is half the size of section T.

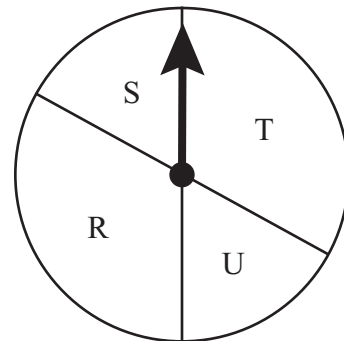

If Darryl spins the arrow one time, what is the probability that it will land on section S?

- A. $\frac{1}{6}$
- B. $\frac{1}{4}$
- C. $\frac{1}{3}$
- D. $\frac{1}{2}$

- 34 Manuel is using a small paper rectangle and a large paper rectangle for an art project.

- The length of the small rectangle is half the length of the large rectangle.
- The width of the small rectangle is half the width of the large rectangle.

The area of the small rectangle is how many times the area of the large rectangle?

- A. $\frac{1}{16}$
- B. $\frac{1}{8}$
- C. $\frac{1}{4}$
- D. $\frac{1}{2}$

- 35 Melinda invested \$1000 in a retirement account. The formula below shows the amount of money, A , that will be in her account at the end of t years.

$$A = 1000(1 + r)^t$$

In the formula, r is the interest rate, expressed as a decimal. Melinda's account has an interest rate of 6%.

Which of the following is closest to the amount that will be in Melinda's account at the end of 2 years?

- A. \$1120
- B. \$1124
- C. \$1256
- D. \$1360

- 36 In circle D , \overline{BC} is a diameter, \overline{DA} is a radius, and $m\widehat{AB} = 60^\circ$.

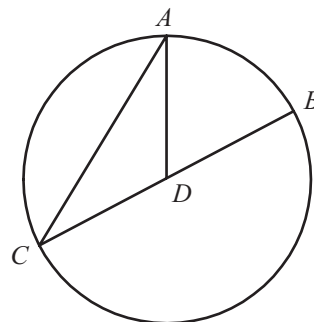

What is $m\angle CAD$?

- A. 30°
- B. 50°
- C. 60°
- D. 70°

- 37 In the diagram below, $\triangle RST$ is equilateral, and U is the midpoint of \overline{RT} .

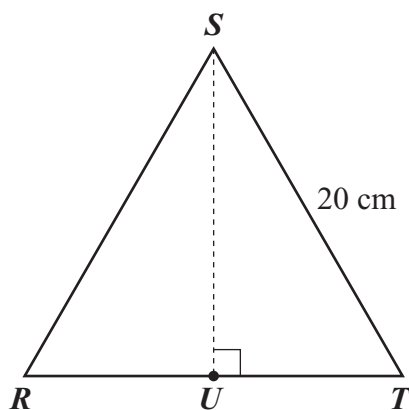

If the length of \overline{ST} is 20 centimeters, what is the length of \overline{SU} ?

- A. 10 cm
- B. $10\sqrt{3}$ cm
- C. 20 cm
- D. $20\sqrt{3}$ cm

- 38 Jeremy calculates his car's gas mileage every time he buys gas for his car. The chart below shows the data from the last 5 times he bought gas.

Gas Mileage for Jeremy's Car

Miles	Gallons of Gas	Gas Mileage (miles per gallon)
370	11.3	32.74
352	9.5	37.05
303	8.9	34.04
298	9.7	30.72
398	11.2	35.54

Based on the data in the chart, what is the range of gas mileage for Jeremy's car?

- A. 2.80 miles per gallon
- B. 4.31 miles per gallon
- C. 4.82 miles per gallon
- D. 6.33 miles per gallon

- 39 The vertex-edge graph below represents all the paths in a park.

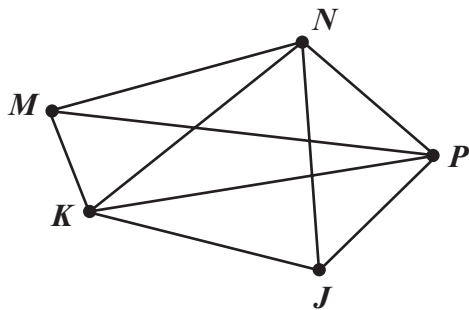

Mike is at point J and wants to walk along each path **exactly** one time. At which point will Mike finish his walk?

- A. point K
- B. point M
- C. point N
- D. point P

- 40 The only coins that Alexis has are dimes and quarters.

- Her coins have a total value of \$5.80.
- She has a total of 40 coins.

Which of the following systems of equations can be used to find the number of dimes, d , and the number of quarters, q , that Alexis has?

- A. $d + q = 5.80$
 $40d + 40q = 5.80$
- B. $d + q = 40$
 $5.80d + 5.80q = 40$
- C. $d + q = 5.80$
 $0.10d + 0.25q = 40$
- D. $d + q = 40$
 $0.10d + 0.25q = 5.80$

Questions 41 and 42 are open-response questions.

- **BE SURE TO ANSWER AND LABEL ALL PARTS OF EACH QUESTION.**
- **Show all your work (diagrams, tables, or computations) in your Student Answer Booklet.**
- **If you do the work in your head, explain in writing how you did the work.**

Write your answer to question 41 in the space provided in your Student Answer Booklet.

- 41 A water dunking tank at a carnival is in the shape of a right circular cylinder. Its height is 5 feet, and the radius of each base is 3 feet, as shown in the picture below.

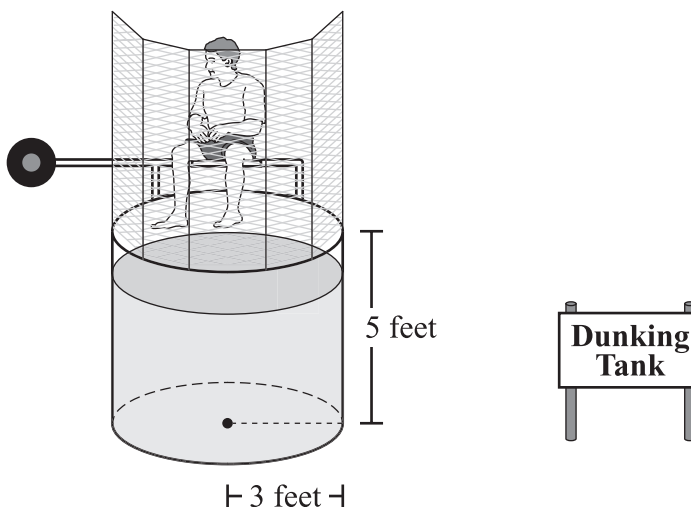

- What is the lateral surface area, in square feet, of the tank? Show your work.
- On the first day of the carnival, the dunking tank was filled with water to a height of 4 feet. What was the volume, in cubic feet, of the water in the tank on the first day of the carnival? Show your work.

At the end of the second day of the carnival, some water was drained from the tank. The volume of water drained was 35.3 cubic feet.

- Using your answer from part (b), determine the height, in feet, of the water remaining in the tank after the water was drained at the end of the second day. Show your work.

The water that was drained from the tank was poured into containers, each in the shape of a right rectangular prism. Each container was 2 feet in length, 1.5 feet in width, and 3 feet in height.

- What was the **least** number of containers needed to hold all the water that was drained at the end of the second day? Show your work.

Write your answer to question 42 in the space provided in your Student Answer Booklet.

- 42 Felicity’s class helped scientists study monarch butterflies. The students caught butterflies, put an identifying tag on each one, and then released them.

The next year scientists caught 24 of the tagged butterflies. They sent Felicity’s class the table below, which shows the distance flown by each of the 24 butterflies.

**Distances Flown by Butterflies
(in miles)**

613	1366	1600	1371	1696	884
842	1886	239	1779	1604	2122
1090	1678	1885	1476	1803	1662
104	1665	1697	1669	120	857

- What is the range of the distances, in miles, that the 24 butterflies flew? Show or explain how you got your answer.
- Copy the table below into your Student Answer Booklet. Complete your table by determining the number of butterflies that flew within each distance interval.

**Distance Intervals
Flown by Butterflies**

Distance Interval (in miles)	Number of Butterflies
0–600	
601–1200	
1201–1800	
1801–2400	

- In your Student Answer Booklet, create a circle graph that shows the information in your table from part (b). Be sure to do the following:
 - Draw the sectors in your circle graph so that their sizes are reasonably accurate.
 - Label each sector of your graph with the distance interval it represents and the percent of the butterflies that flew within that distance interval.
 - Show how you determined each percent.
 - Include a title for your graph.



Massachusetts Comprehensive Assessment System Grade 10 Mathematics Reference Sheet

AREA FORMULAS

square $A = s^2$

rectangle $A = bh$

parallelogram $A = bh$

triangle $A = \frac{1}{2}bh$

trapezoid $A = \frac{1}{2}h(b_1 + b_2)$

circle $A = \pi r^2$

LATERAL SURFACE AREA FORMULAS

right rectangular prism $LA = 2(hw) + 2(lh)$

right circular cylinder $LA = 2\pi rh$

right circular cone $LA = \pi r\ell$
(ℓ = slant height)

right square pyramid $LA = 2s\ell$
(ℓ = slant height)

TOTAL SURFACE AREA FORMULAS

cube $SA = 6s^2$

right rectangular prism $SA = 2(lw) + 2(hw) + 2(lh)$

sphere $SA = 4\pi r^2$

right circular cylinder $SA = 2\pi r^2 + 2\pi rh$

right circular cone $SA = \pi r^2 + \pi r\ell$
(ℓ = slant height)

right square pyramid $SA = s^2 + 2s\ell$
(ℓ = slant height)

VOLUME FORMULAS

cube $V = s^3$
(s = length of an edge)

right rectangular prism $V = lwh$

OR

$V = Bh$
(B = area of a base)

sphere $V = \frac{4}{3}\pi r^3$

right circular cylinder $V = \pi r^2 h$

right circular cone $V = \frac{1}{3}\pi r^2 h$

right square pyramid $V = \frac{1}{3}s^2 h$

CIRCLE FORMULAS

$C = 2\pi r$

$A = \pi r^2$

SPECIAL RIGHT TRIANGLES

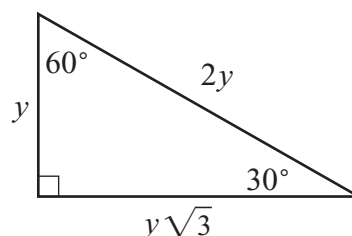
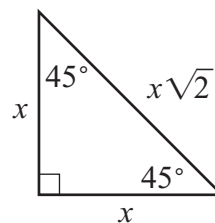

Grade 10 Mathematics
Spring 2008 Released Items:
Reporting Categories, Standards, and Correct Answers*

Item No.	Page No.	Reporting Category	Standard	Correct Answer (MC/SA)*
1	385	<i>Patterns, Relations, and Algebra</i>	10.P.1	B
2	385	<i>Number Sense and Operations</i>	10.N.3	C
3	386	<i>Data Analysis, Statistics, and Probability</i>	10.D.1	C
4	386	<i>Number Sense and Operations</i>	10.N.2	B
5	386	<i>Patterns, Relations, and Algebra</i>	10.P.1	A
6	387	<i>Patterns, Relations, and Algebra</i>	10.P.3	C
7	387	<i>Number Sense and Operations</i>	10.N.3	C
8	387	<i>Patterns, Relations, and Algebra</i>	10.P.5	A
9	388	<i>Data Analysis, Statistics, and Probability</i>	10.D.1	C
10	388	<i>Number Sense and Operations</i>	10.N.2	C
11	388	<i>Number Sense and Operations</i>	10.N.1	A
12	389	<i>Patterns, Relations, and Algebra</i>	10.P.2	D
13	389	<i>Number Sense and Operations</i>	10.N.2	C
14	389	<i>Data Analysis, Statistics, and Probability</i>	10.D.1	A
15	390	<i>Patterns, Relations, and Algebra</i>	10.P.7	$C = 8x + 75$ or equivalent
16	390	<i>Measurement</i>	10.M.1	150 cm ²
17	391	<i>Geometry</i>	10.G.8	
18	392	<i>Data Analysis, Statistics, and Probability</i>	10.D.1	1
19	392	<i>Number Sense and Operations</i>	10.N.2	12
20	393	<i>Number Sense and Operations</i>	8.N.12	
21	394	<i>Patterns, Relations, and Algebra</i>	10.P.7	
22	395	<i>Measurement</i>	10.M.1	A
23	395	<i>Geometry</i>	10.G.3	D
24	396	<i>Patterns, Relations, and Algebra</i>	10.P.2	A
25	396	<i>Patterns, Relations, and Algebra</i>	10.P.7	D
26	397	<i>Geometry</i>	10.G.10	D
27	397	<i>Measurement</i>	10.M.1	B
28	398	<i>Data Analysis, Statistics, and Probability</i>	10.D.1	D
29	398	<i>Number Sense and Operations</i>	10.N.1	C
30	398	<i>Measurement</i>	10.M.1	A
31	399	<i>Patterns, Relations, and Algebra</i>	10.P.1	
32	400	<i>Measurement</i>	10.M.3	B
33	400	<i>Data Analysis, Statistics, and Probability</i>	8.D.4	A
34	401	<i>Measurement</i>	10.M.3	C
35	401	<i>Patterns, Relations, and Algebra</i>	10.P.7	B
36	401	<i>Geometry</i>	10.G.3	A
37	402	<i>Geometry</i>	10.G.6	B
38	402	<i>Data Analysis, Statistics, and Probability</i>	10.D.1	D
39	403	<i>Geometry</i>	10.G.11	B
40	403	<i>Patterns, Relations, and Algebra</i>	10.P.8	D
41	404	<i>Measurement</i>	10.M.2	
42	405	<i>Data Analysis, Statistics, and Probability</i>	10.D.1	

*Answers are provided here for multiple-choice items and short-answer items only. Sample responses and scoring guidelines for open-response items, which are indicated by shaded cells, will be posted to the Department's Web site later this year.

