XI. Mathematics, Grade 5

Grade 5 Mathematics Test

The spring 2008 grade 5 MCAS Mathematics test was based on learning standards in the Massachusetts *Mathematics Curriculum Framework* (2000). The *Framework* identifies five major content strands, listed below. Specific learning standards for grade 5 are found in the *Supplement to the Massachusetts Mathematics Curriculum Framework* (2004). Page numbers for the grades 5–6 *Framework* learning standards and for the grade 5 *Supplement* standards appear in parentheses.

- Number Sense and Operations (*Framework*, pages 25–26; *Supplement*, pages 7–8)
- Patterns, Relations, and Algebra (*Framework*, page 34; *Supplement*, page 8)
- Geometry (*Framework*, page 42; *Supplement*, page 9)
- Measurement (*Framework*, page 50; *Supplement*, pages 9–10)
- Data Analysis, Statistics, and Probability (*Framework*, page 58; *Supplement*, page 10)

The *Mathematics Curriculum Framework* and *Supplement* are available on the Department Web site at www.doe.mass.edu/frameworks/current.html.

In *Test Item Analysis Reports* and on the Subject Area Subscore pages of the *MCAS School Reports* and *District Reports*, Mathematics test results are reported under five MCAS reporting categories, which are identical to the five *Framework* content strands listed above.

Test Sessions

The MCAS grade 5 Mathematics test included two separate test sessions. Each session included multiple-choice, short-answer, and open-response questions.

Reference Materials and Tools

Each student taking the grade 5 Mathematics test was provided with a plastic ruler and a grade 5 Mathematics Reference Sheet. A copy of the reference sheet follows the final question in this chapter. An image of the ruler is not reproduced in this publication.

The use of bilingual word-to-word dictionaries was allowed for current and former limited English proficient students only, during both Mathematics test sessions. No calculators, other reference tools, or materials were allowed.

Cross-Reference Information

The table at the conclusion of this chapter indicates each item's reporting category and the *Framework* learning standard it assesses. The correct answers for multiple-choice and short-answer questions are also displayed in the table.

Mathematics

SESSION 1

You may use your reference sheet and MCAS ruler during this session.
You may **not** use a calculator during this session.



DIRECTIONS

This session contains twelve multiple-choice questions, two short-answer questions, and three open-response questions. Mark your answers to these questions in the spaces provided in your Student Answer Booklet.

- 1 Tina's score from playing a video game is below.

9,050,183

How should Tina write 9,050,183 in words?

- A. nine million, fifty-one thousand, eighty-three
- B. nine million, five thousand, one hundred eighty-three
- C. nine million, fifty thousand, one hundred eighty-three
- D. nine million, five hundred thousand, one hundred eighty-three

- 2 Kareem made the input-output table shown below.

Input	Output
1	4
2	9
3	14
4	19

Which of the following could be the rule for Kareem's input-output table?

- A. Add 3 to the input to get the output.
- B. Add 5 to the input to get the output.
- C. Multiply the input by 3, and then add 1 to the result to get the output.
- D. Multiply the input by 5, and then subtract 1 from the result to get the output.

3 Antonia drew the shape shown on the grid below.

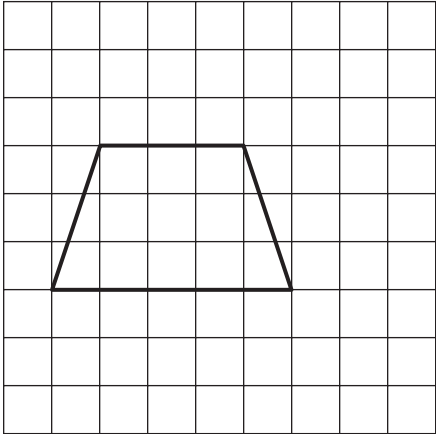

Which of the following shapes is congruent to Antonia's shape?

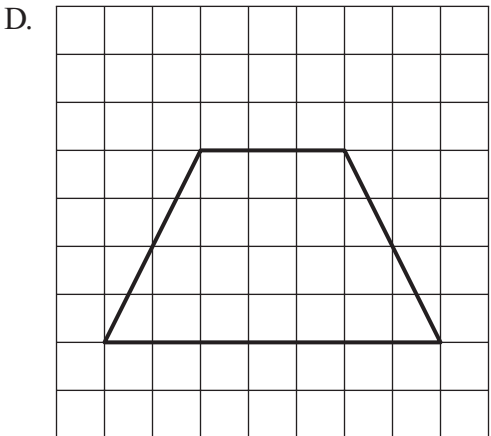
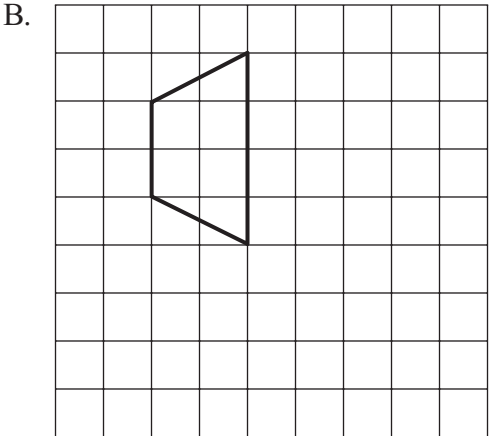
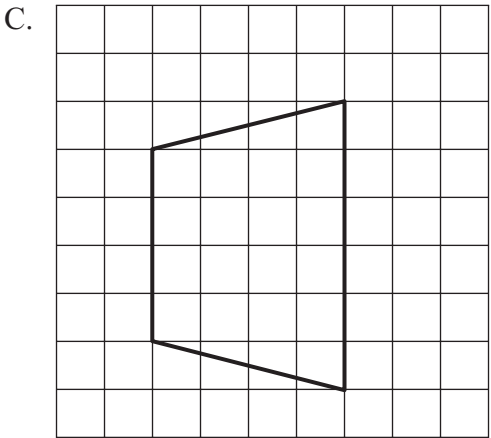
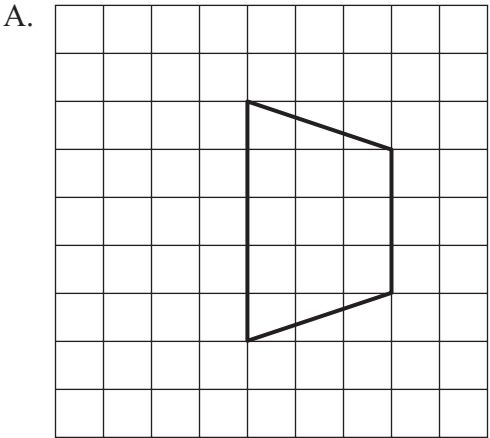

- 4 What is the value of the expression below?

$$5 \times (7 - 4)$$

- A. 15
- B. 31
- C. 39
- D. 55

- 5 What value of \square makes the equation below true?

$$\square \div 4 = 16$$

- A. 4
- B. 12
- C. 20
- D. 64

- 6 The location of point P is shown on the number line below.

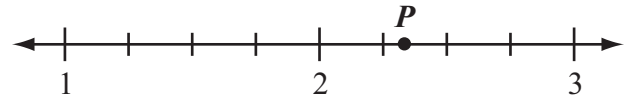

Which of the following numbers is best represented by point P ?

- A. $2\frac{1}{3}$
- B. $2\frac{1}{2}$
- C. $2\frac{2}{3}$
- D. $3\frac{2}{3}$

- 7 Ms. Ortega recorded the number of siblings (brothers and sisters) each student in her class has. Her data are shown on the line plot below.

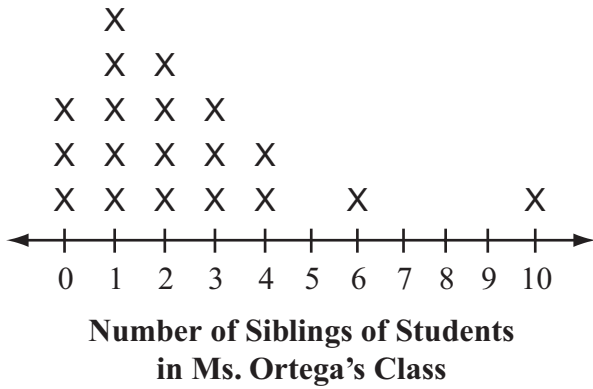

What is the total number of students in Ms. Ortega's class who have **2 or fewer** siblings?

- A. 3
- B. 5
- C. 12
- D. 20

- 8 The 20 students in Petra's class were assigned to five teams, as shown in the table below.

Teams in Petra's Class

Team	Fraction of Class
red	$\frac{1}{5}$
orange	$\frac{3}{10}$
yellow	$\frac{1}{4}$
green	$\frac{3}{20}$
blue	$\frac{1}{10}$

Which team had the **greatest** number of students?

- A. red
- B. orange
- C. yellow
- D. green

9 Which of the following graphs shows distance from home decreasing over time?

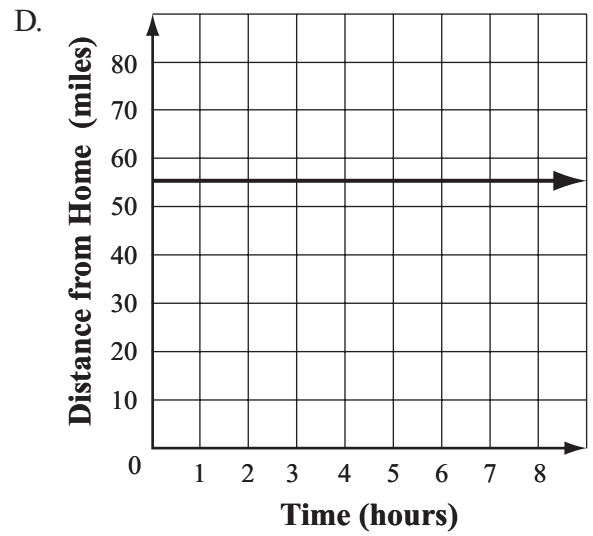
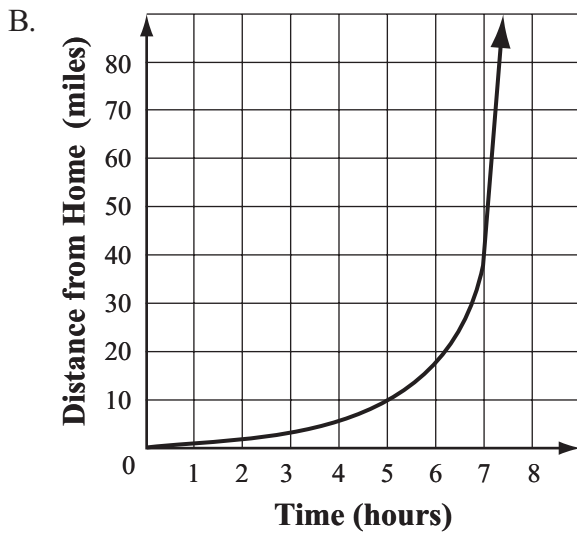
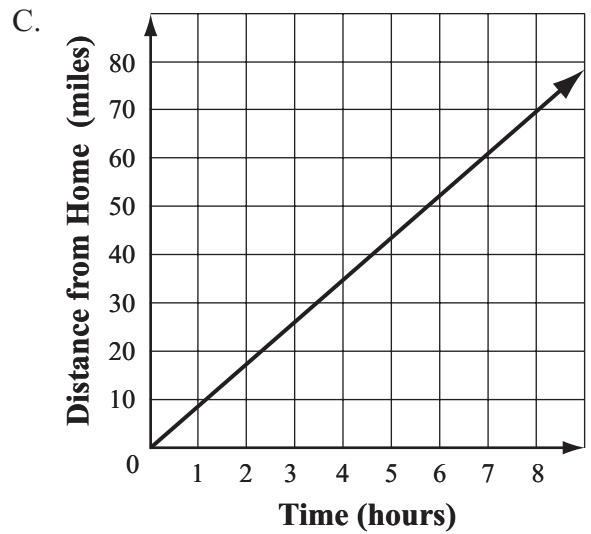
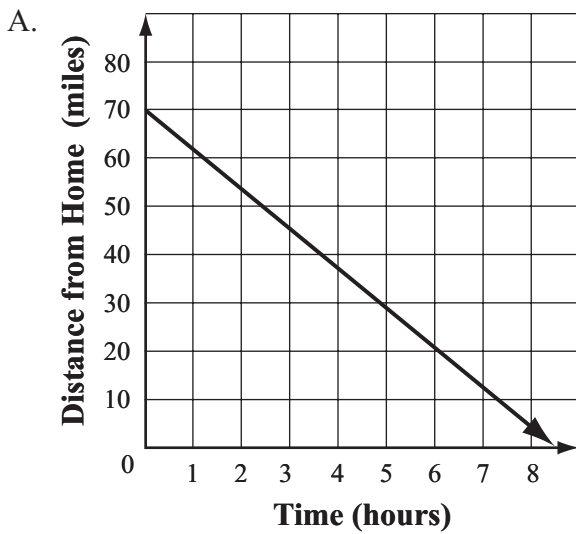

Question 10 is an open-response question.

- **BE SURE TO ANSWER AND LABEL ALL PARTS OF THE QUESTION.**
- **Show all your work (diagrams, tables, or computations) in your Student Answer Booklet.**
- **If you do the work in your head, explain in writing how you did the work.**

Write your answer to question 10 in the space provided in your Student Answer Booklet.

- 10** Karl plays saxophone in a band. The table below shows the number of hours he practiced per week for 7 weeks.

Karl’s Saxophone Practice Times

Week	1	2	3	4	5	6	7
Number of Hours of Practice	8	8	4	8	2	1	4

- a. What is the **median** number of hours Karl practiced per week during the 7 weeks? Show or explain how you got your answer.
- b. What is the **mean** (average) number of hours Karl practiced per week during the 7 weeks? Show or explain how you got your answer.

Suppose Karl had practiced for only 1 hour in Week 1 instead of for 8 hours.

- c. Which measure, the median or the mean, changes more when recalculated with 1 hour of practice in Week 1 instead of 8 hours? Show or explain how you got your answer.

Questions 11 and 12 are short-answer questions. Write your answers to these questions in the boxes provided in your Student Answer Booklet. Do not write your answers in this test booklet. You may do your figuring in the test booklet.

- 11** Haley has a bucket of 100 blocks that are all the same size and shape. The list below shows the number of blocks of each color in the bucket:

- red: 20
- green: 25
- blue: 30
- yellow: 15
- white: 10

Haley takes a block out of the bucket without looking. What is the probability that the block will be green?

- 12** Jerry took \$5.00 to the mall. He spent \$0.85 for a pack of gum and \$3.50 for a comic book. How much money did Jerry have left?

Question 13 is an open-response question.

- **BE SURE TO ANSWER AND LABEL ALL PARTS OF THE QUESTION.**
- **Show all your work (diagrams, tables, or computations) in your Student Answer Booklet.**
- **If you do the work in your head, explain in writing how you did the work.**

Write your answer to question 13 in the space provided in your Student Answer Booklet.

- 13** John's class is studying squares and triangles.
- On the grid in your Student Answer Booklet, draw a square that has an area of 16 square units.
 - On the square you drew in part (a), draw a line that divides the square into 2 congruent triangles.
 - Are the 2 congruent triangles you made in part (b) right triangles? Explain how you know that your answer is correct.
 - Are the 2 congruent triangles you made in part (b) equilateral triangles, isosceles triangles, or neither? Explain how you know that your answer is correct.

Mark your answers to multiple-choice questions 14 through 16 in the spaces provided in your Student Answer Booklet. Do not write your answers in this test booklet. You may do your figuring in the test booklet.

- 14 Angle E is shown below.

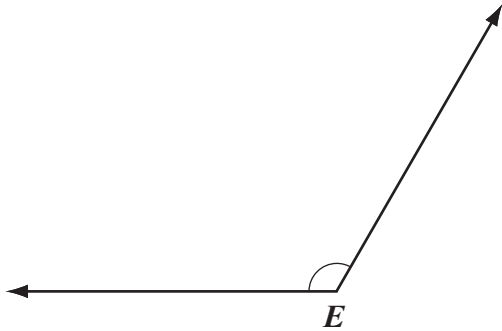

Which of the following best represents the measure of angle E ?

- A. 45°
 B. 80°
 C. 120°
 D. 200°
- 15 Jordan saves \$4 out of every \$10 that she earns from baby-sitting. She saved \$28 of her baby-sitting money last summer.
- How much money did Jordan earn last summer from baby-sitting?
- A. \$32
 B. \$40
 C. \$62
 D. \$70

- 16 A company printed 25,300 magazines. Each magazine had 88 pages.

Which of the following expressions has a value that is closest to the total number of magazine pages the company printed?

- A. $25,000 \times 80$
 B. $25,000 \times 90$
 C. $30,000 \times 90$
 D. $30,000 \times 100$

Question 17 is an open-response question.

- **BE SURE TO ANSWER AND LABEL ALL PARTS OF THE QUESTION.**
- **Show all your work (diagrams, tables, or computations) in your Student Answer Booklet.**
- **If you do the work in your head, explain in writing how you did the work.**

Write your answer to question 17 in the space provided in your Student Answer Booklet.

- 17 Luigi made a pattern using tiles with the same size and shape as the one shown below.



The first four figures in Luigi’s pattern are shown below.

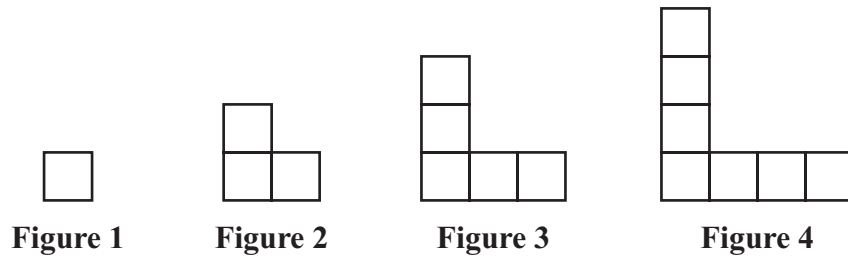

- a. In your Student Answer Booklet, draw Figure 5 of Luigi’s pattern.
- b. What is the total number of tiles needed to make Figure 7 of Luigi’s pattern? Show or explain how you got your answer.
- c. Write or describe a rule that Luigi could use to determine the number of tiles he will need to make Figure n of his pattern. Show or explain how you got your answer.

Mathematics

SESSION 2

You may use your reference sheet and MCAS ruler during this session.
You may **not** use a calculator during this session.



DIRECTIONS

This session contains seventeen multiple-choice questions, three short-answer questions, and two open-response questions. Mark your answers to these questions in the spaces provided in your Student Answer Booklet.

- 18** A travel company assigns one guide for every 8 tourists who go on a tour, as shown in the table below.

Guide Assignments

Number of Tourists	Number of Guides
8	1
16	2
24	3
32	4

Based on this table, what is the total number of guides that will be assigned to 40 tourists?

- A. 5
- B. 6
- C. 7
- D. 8

- 19** Which of the following is equivalent to the expression below?

$$12,950 + 750 - 750$$

- A. $12,950 + 0$
- B. $12,950 \times 0$
- C. $12,950 + 1$
- D. $12,950 - 1$

- 20** Karen bought 15 folders. Each folder cost \$1.24. What was the total cost of Karen's 15 folders?

- A. \$7.44
- B. \$14.40
- C. \$17.40
- D. \$18.60

21 Which of the following figures appears to have $\frac{3}{4}$ shaded?

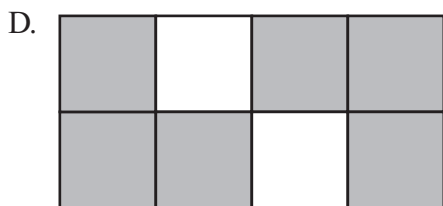
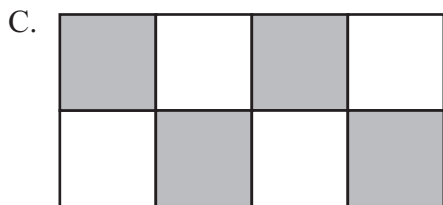
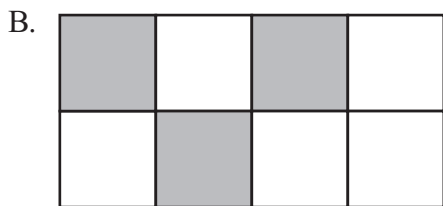
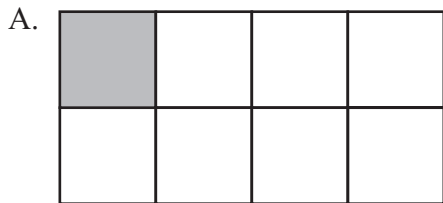

22 Which of the following pairs of line segments appear to be perpendicular to each other?

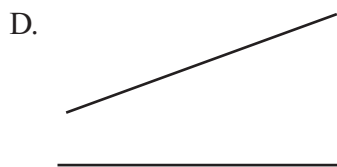
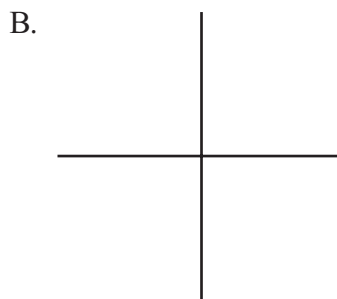

- 23 Maya has a number cube that has faces numbered 1 through 6. She will roll the cube one time.

What is the probability that the number cube will land with a number **less than** 5 showing on the top face?

- A. $\frac{1}{6}$
- B. $\frac{3}{6}$
- C. $\frac{4}{6}$
- D. $\frac{5}{6}$

- 24 Angie used $20\frac{3}{4}$ inches of ribbon to wrap a gift. She also used $15\frac{1}{2}$ inches of ribbon to tie a bag.

What is the total number of inches of ribbon that Angie used?

- A. $35\frac{1}{4}$ inches
- B. $35\frac{2}{3}$ inches
- C. $36\frac{1}{4}$ inches
- D. $36\frac{1}{2}$ inches

- 25 Sam’s printer prints 5 pages in the same amount of time that Heidi’s printer prints 8 pages. What is the total number of pages that Sam’s printer will print in the time it takes Heidi’s printer to print 24 pages?

- A. 13
- B. 15
- C. 16
- D. 19

- 26 On an exercise bicycle, Robin pedaled a total distance of 5 kilometers at a constant speed. The graph below shows the distance Robin pedaled over time.

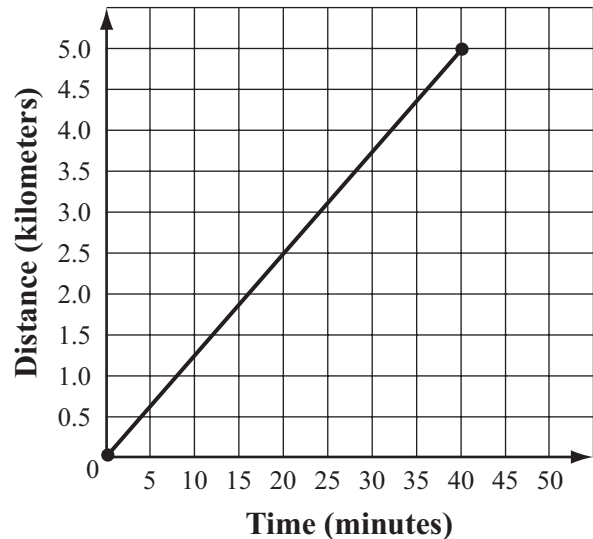

How many minutes did it take Robin to pedal half the total distance?

- A. 20 minutes
- B. 25 minutes
- C. 30 minutes
- D. 35 minutes

Question 27 is an open-response question.

- **BE SURE TO ANSWER AND LABEL ALL PARTS OF THE QUESTION.**
- **Show all your work (diagrams, tables, or computations) in your Student Answer Booklet.**
- **If you do the work in your head, explain in writing how you did the work.**

Write your answer to question 27 in the space provided in your Student Answer Booklet.

- 27 John has a rectangular prism with the dimensions shown in the diagram below.

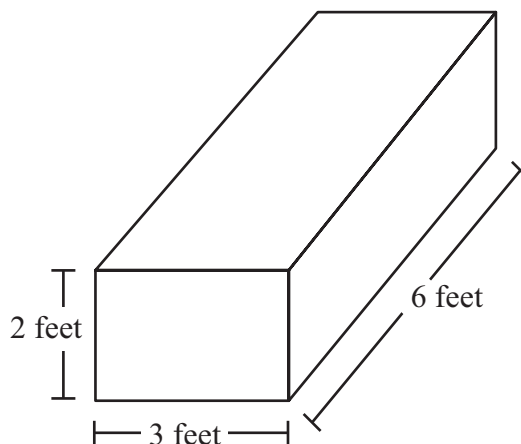

- What is the surface area, in square feet, of John's rectangular prism? Show or explain how you got your answer.
- What is the volume, in cubic feet, of John's rectangular prism? Show or explain how you got your answer.

Maria has a rectangular prism that has different dimensions than John's rectangular prism. Her prism has the same volume as John's prism.

- What could be the dimensions, in feet, of Maria's rectangular prism? Show or explain how you got your answer.

Questions 28, 29, and 30 are short-answer questions. Write your answers to these questions in the boxes provided in your Student Answer Booklet. Do not write your answers in this test booklet. You may do your figuring in the test booklet.

28 A basket contains the apples listed below.

- 9 red apples
- 6 yellow apples
- 5 green apples

What fraction of the apples in the basket are yellow?

29 What is the value of the expression below when $\square = 12$?

$$60 \div \square$$

Write your answer to question 30 in the box provided in your Student Answer Booklet.

- 30 Hilary drew a triangle and labeled its vertices J , K , and L .
- The measure of angle J is 60° .
 - The measure of angle K is 35° .

What is the measure, in degrees, of angle L ?

Question 31 is an open-response question.

- **BE SURE TO ANSWER AND LABEL ALL PARTS OF THE QUESTION.**
- **Show all your work (diagrams, tables, or computations) in your Student Answer Booklet.**
- **If you do the work in your head, explain in writing how you did the work.**

Write your answer to question 31 in the space provided in your Student Answer Booklet.

- 31** The fifth-grade marching band includes boys and girls.
- There are 28 boys in the marching band.
 - The 28 boys are $\frac{7}{10}$ of the students in the marching band.
- a. What fraction of the students in the marching band are **girls**? Show or explain how you got your answer.
- b. What is the total number of students in the marching band? Show or explain how you got your answer.

Mark your answers to multiple-choice questions 32 through 39 in the spaces provided in your Student Answer Booklet. Do not write your answers in this test booklet. You may do your figuring in the test booklet.

- 32 Betty drew the figure shown below.

Betty's Figure

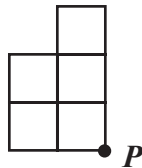

Which of the following shows Betty's figure after it has been rotated 90° clockwise about point P?

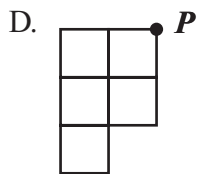
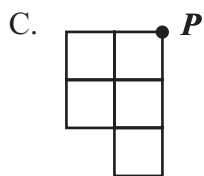
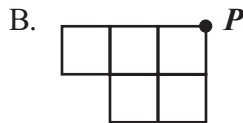
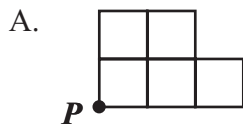

- 33 Which of the following is another way to write 10^6 ?

- A. ten thousand
- B. one hundred thousand
- C. one million
- D. ten million

- 34 Chen wrote a number pattern.

- He used the rule “multiply by 2.”
- The 4th number in his pattern was 24.

What was the 1st number in Chen's number pattern?

- A. 2
- B. 3
- C. 6
- D. 12

- 35 The floor in Steve's room is shaped like a rectangle.
- It has an area of 168 square feet.
 - It has a width of 12 feet.

What is the length of Steve's room?

- A. 14 feet
B. 28 feet
C. 72 feet
D. 84 feet
- 36 Jen uses $\frac{3}{4}$ cup of butter for every 1 batch of cookies that she bakes. How many cups of butter will Jen use when she bakes 6 batches of cookies?
- A. $4\frac{1}{2}$ cups
B. 5 cups
C. $6\frac{3}{4}$ cups
D. 8 cups

- 37 The poster shown below describes the DVD sale that Martin's Video is having.



What is the greatest number of DVDs that can be bought for \$45 at Martin's Video during this DVD sale?

- A. 6
B. 9
C. 15
D. 30

- 38 Mr. Chang surveyed the fifth-grade students about where they would most like to go for a field trip. The results of the survey are shown in the graph below.

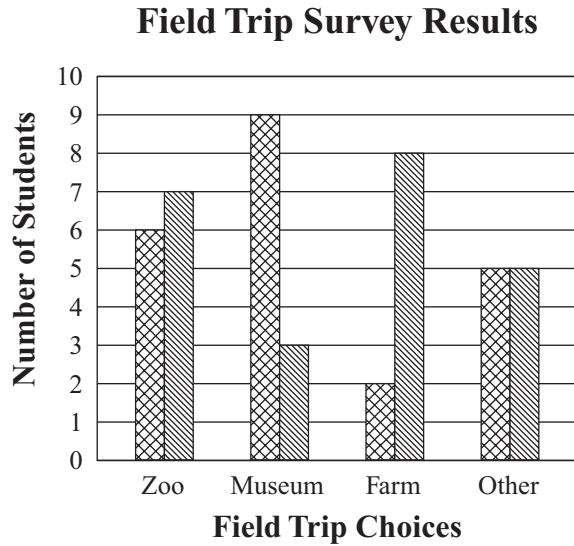

Key	
⊠	Boys
▨	Girls

Based on the graph, where would the greatest number of fifth-grade students most like to go for a field trip?

- A. zoo
- B. museum
- C. farm
- D. other

- 39 Which of the following numbers is **not** equivalent to 40%?

- A. 0.04
- B. 0.40
- C. $\frac{2}{5}$
- D. $\frac{4}{10}$

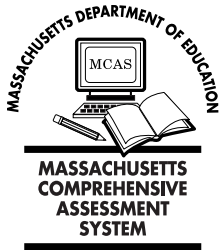

Massachusetts Comprehensive Assessment System Grade 5 Mathematics Reference Sheet

PERIMETER (P) FORMULAS

perimeter = distance around

square $P = 4 \times s$
(s = length of a side)

rectangle $P = (2 \times l) + (2 \times w)$
(l = length; w = width)

triangle $P = a + b + c$
(a , b , and c are the lengths of the sides)

VOLUME (V) FORMULAS

rectangular prism $V = l \times w \times h$
(l = length; w = width; h = height)

cube $V = s \times s \times s$
(s = length of an edge)

AREA (A) FORMULAS

square $A = s \times s$
(s = length of a side)

rectangle $A = l \times w$
(l = length; w = width)

triangle $A = \frac{1}{2} \times b \times h$
(b = length of the base;
 h = height)

Grade 5 Mathematics
Spring 2008 Released Items:
Reporting Categories, Standards, and Correct Answers*

Item No.	Page No.	Reporting Category	Standard	Correct Answer (MC/SA)*
1	287	<i>Number Sense and Operations</i>	5.N.3	C
2	287	<i>Patterns, Relations, and Algebra</i>	5.P.4	D
3	288	<i>Geometry</i>	5.G.7	A
4	289	<i>Number Sense and Operations</i>	5.N.10	A
5	289	<i>Patterns, Relations, and Algebra</i>	5.P.3	D
6	289	<i>Number Sense and Operations</i>	5.N.6	A
7	290	<i>Data Analysis, Statistics, and Probability</i>	5.D.2	C
8	290	<i>Number Sense and Operations</i>	5.N.7	B
9	291	<i>Patterns, Relations, and Algebra</i>	5.P.6	A
10	292	<i>Data Analysis, Statistics, and Probability</i>	5.D.1	
11	293	<i>Data Analysis, Statistics, and Probability</i>	5.D.3	$\frac{1}{4}$ or equivalent
12	293	<i>Number Sense and Operations</i>	5.N.12	\$0.65
13	294	<i>Geometry</i>	5.G.1	
14	295	<i>Measurement</i>	5.M.2	C
15	295	<i>Patterns, Relations, and Algebra</i>	5.P.5	D
16	295	<i>Number Sense and Operations</i>	5.N.14	B
17	296	<i>Patterns, Relations, and Algebra</i>	5.P.1	
18	297	<i>Patterns, Relations, and Algebra</i>	5.P.4	A
19	297	<i>Number Sense and Operations</i>	5.N.11	A
20	297	<i>Number Sense and Operations</i>	5.N.12	D
21	298	<i>Number Sense and Operations</i>	5.N.4	D
22	298	<i>Geometry</i>	5.G.3	B
23	299	<i>Data Analysis, Statistics, and Probability</i>	5.D.3	C
24	299	<i>Number Sense and Operations</i>	5.N.13	C
25	299	<i>Patterns, Relations, and Algebra</i>	5.P.5	B
26	299	<i>Patterns, Relations, and Algebra</i>	5.P.6	A
27	300	<i>Measurement</i>	5.M.4	
28	301	<i>Number Sense and Operations</i>	5.N.4	$\frac{3}{10}$ or equivalent
29	301	<i>Patterns, Relations, and Algebra</i>	5.P.2	5
30	302	<i>Measurement</i>	5.M.5	85°
31	303	<i>Number Sense and Operations</i>	5.N.4	
32	304	<i>Geometry</i>	5.G.5	A
33	304	<i>Number Sense and Operations</i>	5.N.1	C
34	304	<i>Patterns, Relations, and Algebra</i>	5.P.1	B
35	305	<i>Measurement</i>	5.M.1	A
36	305	<i>Number Sense and Operations</i>	5.N.9	A
37	305	<i>Patterns, Relations, and Algebra</i>	5.P.5	B
38	306	<i>Data Analysis, Statistics, and Probability</i>	5.D.2	A
39	306	<i>Number Sense and Operations</i>	5.N.5	A

* Answers are provided here for multiple-choice items and short-answer items only. Sample responses and scoring guidelines for open-response items, which are indicated by shaded cells, will be posted to the Department's Web site later this year.