XXI. Technology/Engineering,
High School

High School Technology/Engineering Test

The spring 2010 high school MCAS Technology/Engineering test was based on learning standards in the Technology/Engineering content strand of the Massachusetts *Science and Technology/Engineering Curriculum Framework* (2006). These learning standards appear on pages 92–95 of the *Framework*.

The *Science and Technology/Engineering Curriculum Framework* is available on the Department website at www.doe.mass.edu/frameworks/current.html.

In test item analysis reports and on the Subject Area Subscore pages of the MCAS *School Reports* and *District Reports*, Technology/Engineering test results are reported under the following four MCAS reporting categories:

- Engineering Design
- Construction and Manufacturing
- Fluid and Thermal Systems
- Electrical and Communications Systems

Test Sessions

The MCAS high school Technology/Engineering test included two separate test sessions, which were administered on consecutive days. Each session included multiple-choice and open-response questions.

Reference Materials and Tools

Each student taking the high school Technology/Engineering test was provided with a plastic ruler and a Technology/Engineering Formula Sheet. A copy of this formula sheet follows the final question in this chapter. An image of the ruler is not reproduced in this publication.

Each student also had sole access to a calculator with at least four functions and a square-root key.

The use of bilingual word-to-word dictionaries was allowed for current and former limited English proficient students only, during both Technology/Engineering test sessions. No other reference tools or materials were allowed.

Cross-Reference Information

The table at the conclusion of this chapter indicates each item's reporting category and the framework learning standard it assesses. The correct answers for multiple-choice questions are also displayed in the table.

Technology/Engineering

SESSION 1

DIRECTIONS

This session contains twenty-one multiple-choice questions and two open-response questions. Mark your answers to these questions in the spaces provided in your Student Answer Booklet. You may work out solutions to multiple-choice questions in the test booklet.

1 An architect is designing a house to be built in Maine. Which of the following features would maximize both passive solar heating and the amount of natural light inside the house?

- A. a high gable roof
- B. light-colored vinyl siding
- C. solar-electric panels on the roof
- D. a large number of south-facing windows

2 In a factory that manufactures automobiles, some workers have the job of installing doors on the cars. Which part of the manufacturing process is this job?

- A. forming
- B. finishing
- C. conditioning
- D. assembling

3 Sarah presented an idea for recycling used tires to an automotive company. If she followed the engineering design process, what was the **first** step in developing her idea?

- A. communicating the results of her research
- B. developing a prototype she wanted to make
- C. selecting the best possible solution to her problem
- D. identifying the specific problem she wanted to solve

4 The drawing below represents a metal bar subjected to forces at both ends. The dotted line indicates the axis along which the forces are applied.

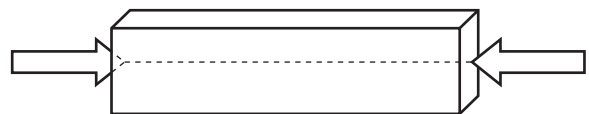

Which of the following is the type of stress being exerted on the bar?

- A. compression
- B. shear
- C. tension
- D. torsion

- 5 A farmer places a sprinkler on top of a platform in the middle of a field. Water is pumped to the sprinkler from a water supply tank. The spray from the sprinkler, however, does not reach the edges of the field.

Which of the following should the farmer do to increase the range of the sprinkler?

- A. Place the sprinkler at ground level.
- B. Reduce the diameter of the sprinkler nozzle.
- C. Move the water supply tank closer to the field.
- D. Increase the diameter of the water supply tank.

- 6 The diagram below shows the flow of water in a section of a piping system.

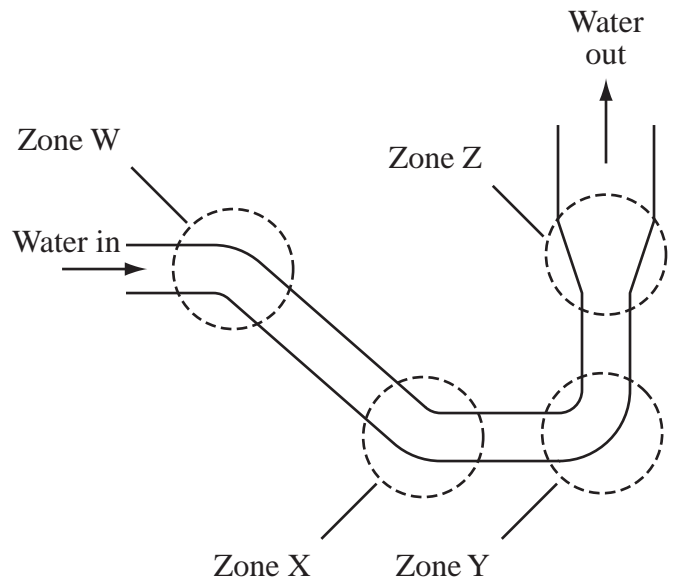

Which zone has the **highest** resistance to the flow of water?

- A. zone W
- B. zone X
- C. zone Y
- D. zone Z

- 7 A DC to AC inverter allows people to use AC devices in a car. This inverter converts 12 V DC from a car outlet to 110 V AC.

Which of the following graphs **best** represents the output signal of the inverter?

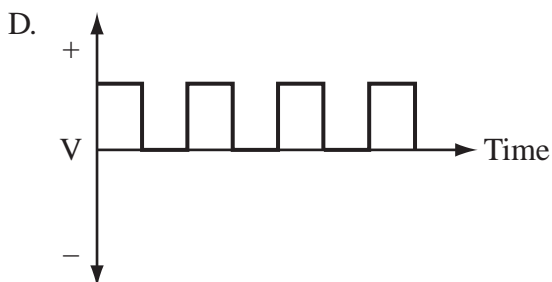
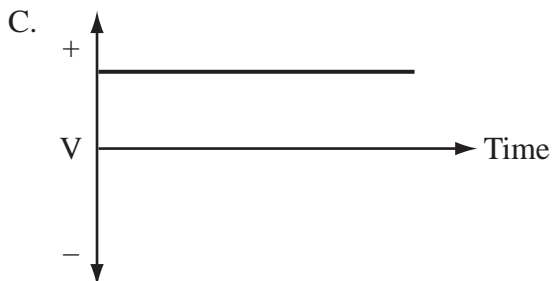
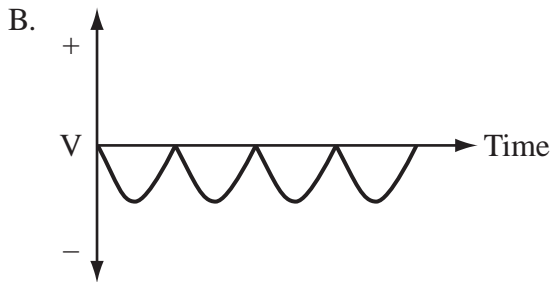
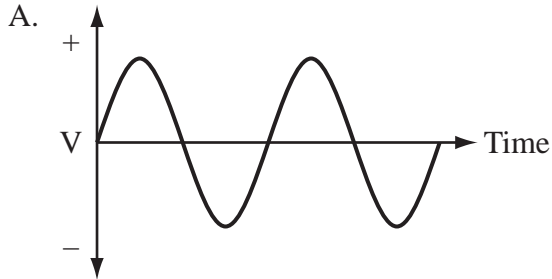

- 8 A manufacturing company wants to increase its production. Which of the following is the **best** reason why the company should consider using robotic systems?

- A. Robotic systems are easy to operate.
- B. Robotic systems can function continuously.
- C. Robotic systems are inexpensive to purchase.
- D. Robotic systems are more intelligent than human workers.

- 9 How many views are usually necessary in order to describe an object using an orthographic projection?

- A. 1 or 2
- B. 2 or 3
- C. 4 or 5
- D. 5 or 6

- 10 DC voltage sources have a positive (+) terminal and a negative (−) terminal. Which of the following statements explains why AC voltage sources do not have positive and negative terminals?
- A. AC voltage at each terminal is always changing.
 - B. AC current does not involve charged particles.
 - C. AC current is safe and warning labels are not needed.
 - D. AC voltage at each terminal is always higher than ground.

Question 11 is an open-response question.

- **BE SURE TO ANSWER AND LABEL ALL PARTS OF THE QUESTION.**
- **Show all your work (diagrams, tables, or computations) in your Student Answer Booklet.**
- **If you do the work in your head, explain in writing how you did the work.**

Write your answer to question 11 in the space provided in your Student Answer Booklet.

11 A single sheet of plywood can be cut to produce several smaller pieces.

- a. On the grid provided in your Student Answer Booklet, draw a $4' \times 8'$ piece of plywood using the scale $\frac{1}{6}'' = 6''$.
- b. On your drawing, mark the lines necessary to obtain the following pieces (ignore blade thickness):
 - one $1' \times 8'$
 - two $1' \times 4'$
 - one $2' \times 3'$
 - two $1' \times 2'$
 - one $2' \times 2'$
- c. Is there any wood left over? If so, what are the dimensions of the waste?

Mark your answers to multiple-choice questions 12 through 22 in the spaces provided in your Student Answer Booklet. Do not write your answers in this test booklet, but you may work out solutions to multiple-choice questions in the test booklet.

- 12 Which of the following is considered a nonrenewable energy source?
- A. sunlight
 - B. uranium
 - C. wind
 - D. wood

- 13 A series circuit with two resistors is shown below.

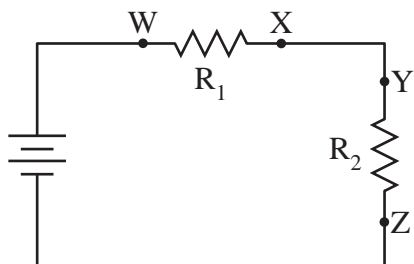

At which two points should a voltmeter be connected to measure the voltage of the circuit?

- A. points Y and Z
- B. points W and X
- C. points X and Y
- D. points W and Z

- 14 A working diagram for a prototype of a motor is shown below.

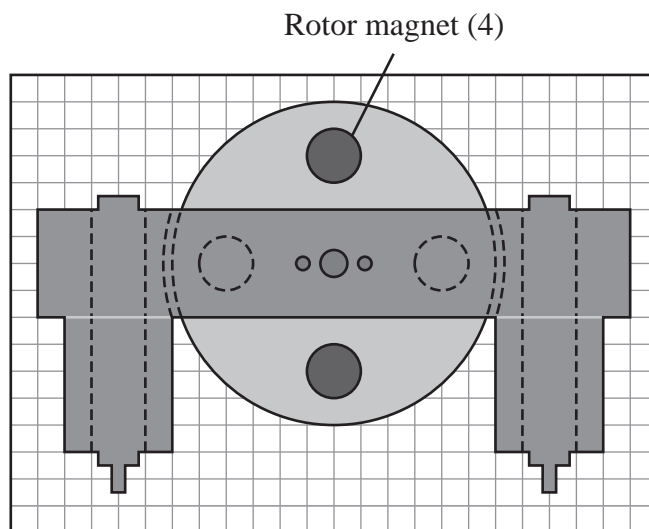

Key	
□	represents 1.0 sq. in.

What is the diameter of **one** of the rotor magnets?

- A. 1.0 in.
- B. 2.0 in.
- C. 4.0 in.
- D. 8.0 in.

15 Information produced by technological devices can travel through optical fiber, air, and space. Which of the following statements describes what these media have in common?

- A. Information travels through these media at the same speed.
- B. Information travels through these media at a single frequency.
- C. Information travels through these media using mechanical waves.
- D. Information travels through these media using electromagnetic waves.

16 One type of hydraulic system is designed to lift heavy objects. Which of the following statements **best** explains this application?

- A. The hydraulic system acts as a force multiplier.
- B. The hydraulic system acts as a work multiplier.
- C. The hydraulic system acts as a power multiplier.
- D. The hydraulic system acts as an energy multiplier.

17 The electrical resistance of a wire may change depending on which of the following?

- A. the luster of the wire
- B. the elasticity of the wire
- C. the malleability of the wire
- D. the temperature of the wire

18 A simple circuit diagram is shown below.

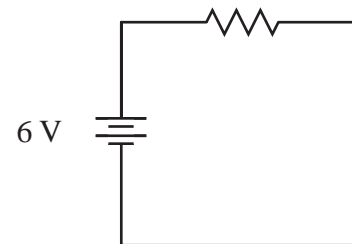

What is the resistance of the circuit if the current is 0.5 A?

- A. 3.0 Ω
- B. 9.0 Ω
- C. 12.0 Ω
- D. 24.0 Ω

- 19 Meaghan is going to use the air-powered tool shown below.

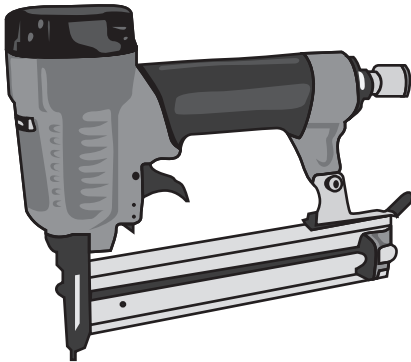

She has never used this tool before. Which of the following should Meaghan do first before using this tool?

- A. release the safety trigger
- B. read the operational manual thoroughly
- C. use an extension cord to plug in the tool
- D. make sure the tool is connected to an air supply

- 20 Before releasing a newly designed video game to the public, the developer distributes the game to a few hundred people free of charge. After playing the game, the people complete a survey and return it to the developer.

What part of the engineering design process does this scenario represent?

- A. redesign
- B. testing and evaluation
- C. selection of a solution
- D. construction of prototypes

21 When calculators were first introduced, they were large and not very portable. Which of the following allowed for the development of pocket-size calculators?

- A. direct current
- B. fewer function keys
- C. graphing software
- D. smaller microprocessors

22 For a manufacturing process, the cutting edges of the separating tool should typically have which of the following characteristics?

- A. They should be harder than the material being cut.
- B. They should be cleaner than the material being cut.
- C. They should be more porous than the material being cut.
- D. They should be more flexible than the material being cut.

Question 23 is an open-response question.

- **BE SURE TO ANSWER AND LABEL ALL PARTS OF THE QUESTION.**
- **Show all your work (diagrams, tables, or computations) in your Student Answer Booklet.**
- **If you do the work in your head, explain in writing how you did the work.**

Write your answer to question 23 in the space provided in your Student Answer Booklet.

- 23 The drawing below is a floor plan for part of a house.

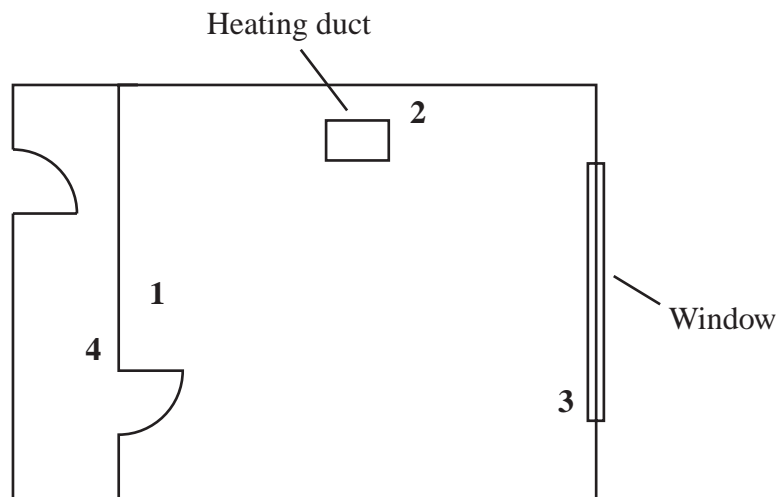

A thermostat for the heating system will control the temperature in the large room. Four possible locations for the thermostat are shown on the plan.

Explain why **each** of the four numbered locations either is or is not a good place for the thermostat. Include the relevant heat transfer methods for each location in your answer.

Technology/Engineering

SESSION 2

DIRECTIONS

This session contains nineteen multiple-choice questions and three open-response questions. Mark your answers to these questions in the spaces provided in your Student Answer Booklet. You may work out solutions to multiple-choice questions in the test booklet.

- 24 During World War II, signal lights were used to send Morse code messages between ships. A sailor would open and close a shutter over a light source to send “dots” and “dashes” of light to another ship.

The sailor performed the function of which component of a communication system?

- A. decoder
- B. destination
- C. encoder
- D. receiver

- 25 A current of 1.2 A flows through a 5.0Ω resistor in a circuit. What is the voltage across this resistor?

- A. 0.24 V
- B. 3.8 V
- C. 6.0 V
- D. 7.5 V

- 26 The figure below shows water being heated in a pan on a gas burner.

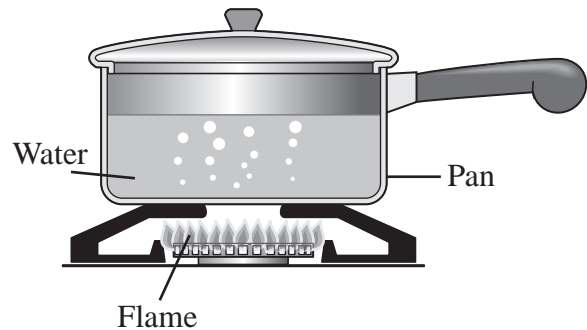

Which of the following identifies a heat transfer primarily due to radiation?

- A. from the wall of the pan to the cover
- B. from the pan to the surface of the water
- C. from the flame to the bottom of the pan
- D. from the surface of the water to the handle of the pan

- 27 Telephone circuits were originally made of copper. Which of the following has replaced much of the copper circuitry that connected telephone switching stations over long distances?
- A. fiberoptic cables
 - B. reinforced plastics
 - C. superconductors
 - D. tungsten wires
- 28 Which of the following causes the **greatest** resistance to water flowing through a PVC piping system?
- A. elbows
 - B. gaskets
 - C. insulation
 - D. rust
- 29 Which of the following functions can a variable resistor perform?
- A. storing electrical charge
 - B. adjusting light intensity
 - C. creating electrical energy
 - D. controlling current direction

- 30 Which of the following is an example of an open fluid system?
- A. an irrigation system for a farm
 - B. a forced hot water heater for a house
 - C. a hydraulic braking system for a truck
 - D. a cooling system for an automobile engine
- 31 During a hurricane, winds can blow out windows and walls, or remove the roof from a house. According to Bernoulli's principle, which of the following statements best explains why this can occur?
- A. Wind blowing around and over a house creates convection currents outside the house.
 - B. Wind blowing around and over a house is at a lower pressure than the air inside the house.
 - C. Wind blowing around and over a house is at a higher temperature than the air inside the house.
 - D. Wind blowing around and over a house creates electrostatic charges in the air around the house.
- 32 Which of the following describes the primary function of an alkaline battery in the circuit of a typical flashlight?
- A. It opens and closes the circuit path.
 - B. It provides resistance to generate light.
 - C. It converts chemical energy to electrical energy for the circuit.
 - D. It serves as a conductor through which electrical energy flows.

Question 33 is an open-response question.

- **BE SURE TO ANSWER AND LABEL ALL PARTS OF THE QUESTION.**
- **Show all your work (diagrams, tables, or computations) in your Student Answer Booklet.**
- **If you do the work in your head, explain in writing how you did the work.**

Write your answer to question 33 in the space provided in your Student Answer Booklet.

33 The diagrams below represent a hydraulic system and a pneumatic system.

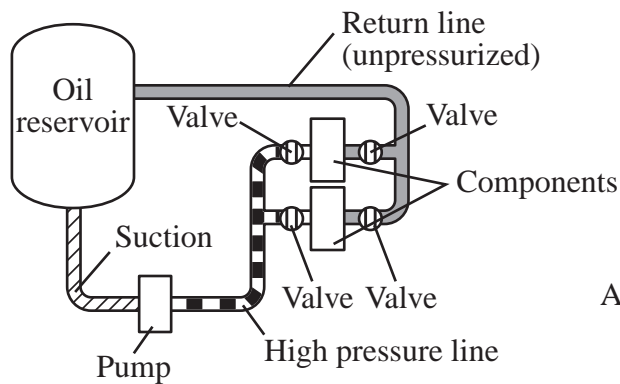

System X

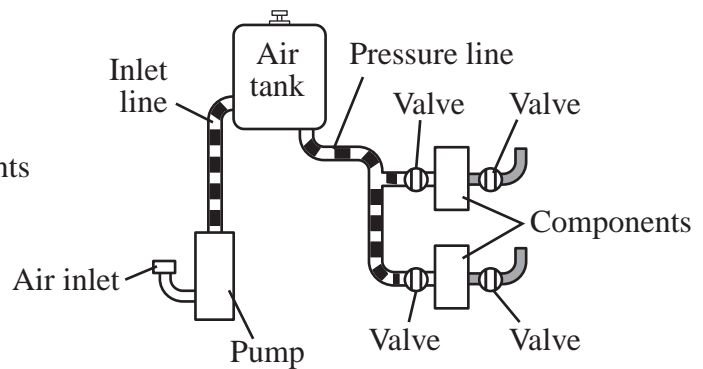

System Y

These two systems are similar in function, but system X uses oil while system Y uses air.

- Identify which system is hydraulic and which system is pneumatic.
- Describe one application of a hydraulic system **and** one application of a pneumatic system in manufacturing or transportation.
- Describe one advantage **and** one disadvantage of each type of system.

Mark your answers to multiple-choice questions 34 through 43 in the spaces provided in your Student Answer Booklet. Do not write your answers in this test booklet, but you may work out solutions to multiple-choice questions in the test booklet.

- 34 Lasers produce coherent light. Which of the following drawings **best** represents coherent light?

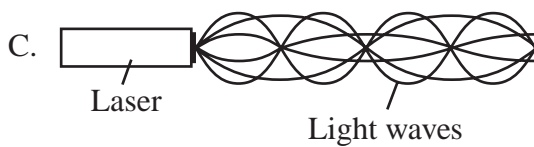
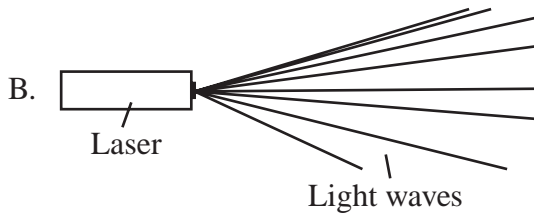
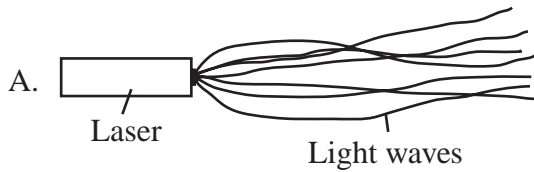

- 35 The floor of a particular motel room should be able to support 50 lb. per sq. ft. of live load. If the dimensions of the room are 12 ft. \times 15 ft., what is the total live load that the floor should support?

- A. 600 lb.
B. 750 lb.
C. 1350 lb.
D. 9000 lb.

- 36 Which of the following are represented using binary values?
- A. analog signals
 - B. digital signals
 - C. gamma rays
 - D. ultraviolet rays
- 37 Since the introduction of the cellular phone, many advances in wireless communication have been made. Which of the following features has been added to cellular phones for the purpose of finding someone who has placed an emergency call?
- A. caller identification
 - B. digital camera
 - C. global positioning system
 - D. text messaging
- 38 Which of the following matches a communication medium with a type of signal that can be readily transmitted through it?
- A. copper wire—electric
 - B. copper wire—infrared
 - C. optical fiber—radio
 - D. optical fiber—x-ray
- 39 Message signs and arrow boards are used to direct traffic and safeguard workers on roads and highways. These devices were originally run by diesel-powered generators.
- Which of the following provides a practical way to power these mobile devices and is more efficient than a generator?
- A. natural gas
 - B. water power
 - C. a geothermal system
 - D. a solar conversion system

- 40 The diagram below shows a basic construction diagram for framing a deck.

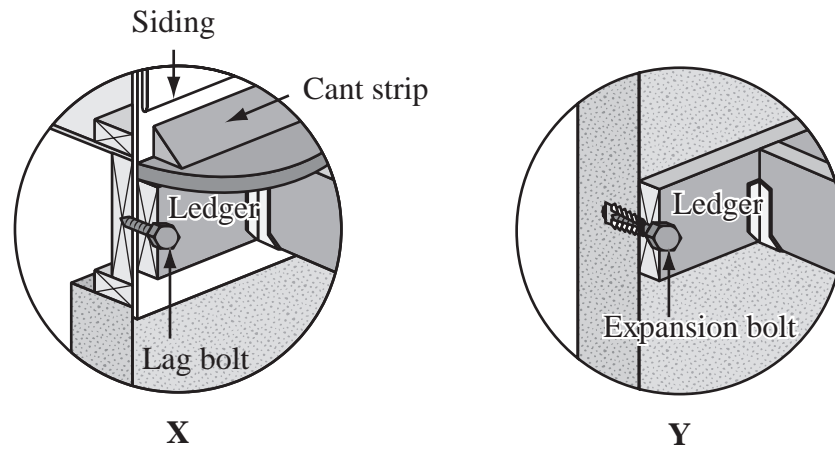
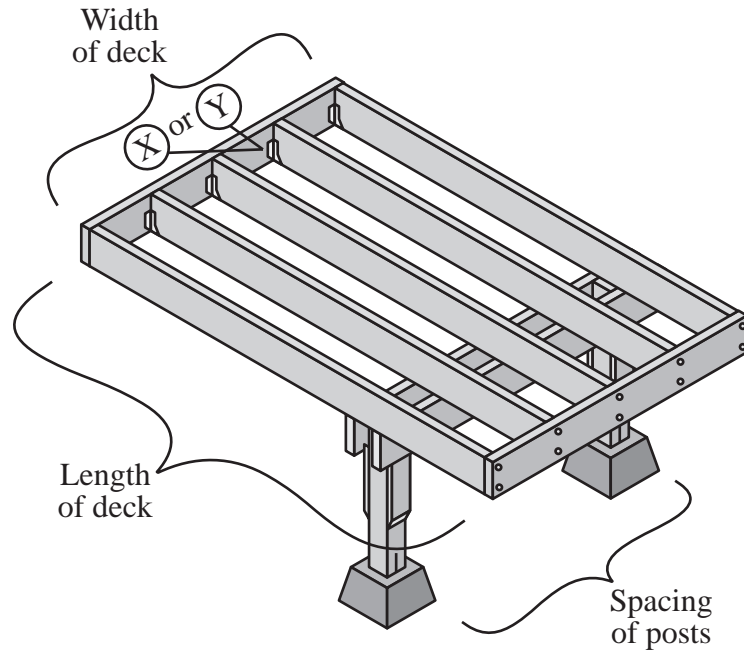

Which of the following statements best explains why the details shown in X and Y are provided?

- A. The length of the deck may vary.
- B. The width of the deck may vary.
- C. The posts may sit on different types of foundations.
- D. The deck may be attached to structures made of different materials.

- 41 A contractor needs to choose a low-density material for use in the construction of a building. When comparing two materials of the same size, the less dense material always gives a building structure which of the following characteristics?

A. lower weight
 B. greater strength
 C. lower flammability
 D. greater electrical conductivity

- 42 A scale drawing of a rectangular storage tank has a scale of 1 cm = 0.5 m. The dimensions of the tank on the drawing are 24 cm × 32 cm × 20 cm.

What are the dimensions of the actual storage tank?

A. 2.4 m × 3.2 m × 2.0 m
 B. 4.8 m × 6.4 m × 4.0 m
 C. 12 m × 16 m × 10 m
 D. 48 m × 64 m × 40 m

- 43 A diagram of a solar water heating system is shown below.

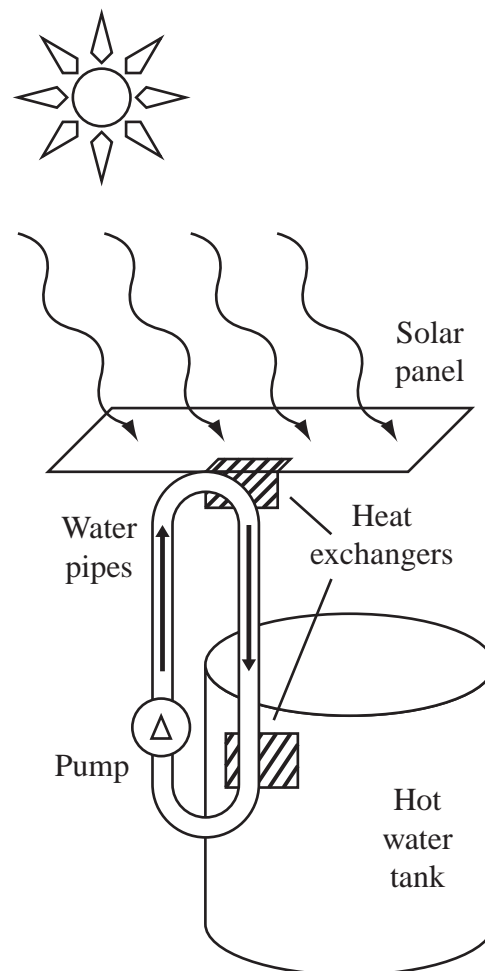

The system is designed to transfer heat from the solar panel to the hot water tank. The heat is transferred to and from the water pipes through heat exchangers. The system will be most efficient if the heat exchangers are made of which of the following materials?

A. copper
 B. glass
 C. porcelain
 D. plastic

Questions 44 and 45 are open-response questions.

- **BE SURE TO ANSWER AND LABEL ALL PARTS OF EACH QUESTION.**
- **Show all your work (diagrams, tables, or computations) in your Student Answer Booklet.**
- **If you do the work in your head, explain in writing how you did the work.**

Write your answer to question 44 in the space provided in your Student Answer Booklet.

- 44 John and Samantha are moving to a city. They would like to open a music store. The building they want to buy includes enough space for the store, living quarters for John and Samantha, and a room in which John can practice the drums after the store closes at night. Before agreeing to make an offer on the property, John and Samantha go to the city hall to check the city zoning laws.
- a. Identify **two** specific zoning laws that John and Samantha should check.
 - b. Explain how **each** zoning law you identified in part (a) would affect John and Samantha's decision on purchasing the property.

Write your answer to question 45 in the space provided in your Student Answer Booklet.

- 45 A student looking into the front of a glass aquarium filled with water notices that she cannot see through the right or left sides of the aquarium. She investigates this observation by aiming a laser pointer at the front of the aquarium and observing the path of the light. Her results are shown in the diagram below.

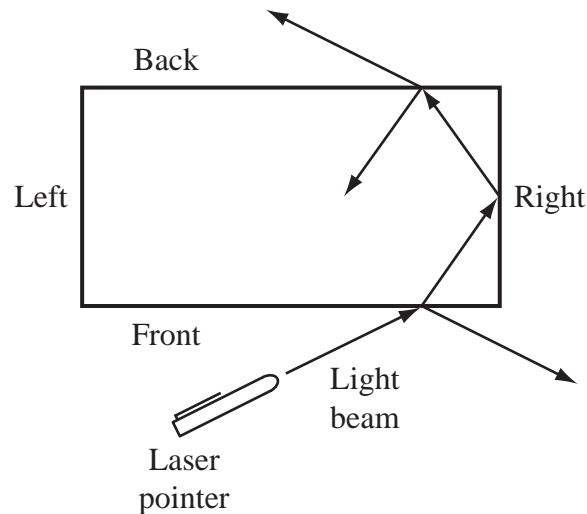

- Describe what happens to the light that strikes the front glass panel of the aquarium **and** the light that strikes the right glass panel of the aquarium.
- Describe in detail how the behavior of light in the student's investigation relates to fiberoptic data transmission.



Formulas

$$V = I \times R$$

$$\text{Pressure} = \frac{\text{Force}}{\text{Area}}$$

$$P = I \times V$$

$$\text{Area of a circle} = \pi r^2$$

Variables

I = current

r = radius

P = power

R = resistance

V = voltage

Definitions and Abbreviations

AC = alternating current

psi = pounds per square inch

DC = direct current

$\pi \approx 3.14$

**High School Technology/Engineering
Spring 2010 Released Items:
Reporting Categories, Standards, and Correct Answers***

Item No.	Page No.	Reporting Category	Standard	Correct Answer (MC)*
1	364	<i>Fluid and Thermal Systems</i>	4.3	D
2	364	<i>Construction and Manufacturing</i>	7.1	D
3	364	<i>Engineering Design</i>	1.1	D
4	364	<i>Construction and Manufacturing</i>	2.2	A
5	365	<i>Fluid and Thermal Systems</i>	3.4	B
6	365	<i>Fluid and Thermal Systems</i>	3.5	C
7	366	<i>Electrical and Communication Systems</i>	5.5	A
8	366	<i>Construction and Manufacturing</i>	7.3	B
9	366	<i>Engineering Design</i>	1.3	B
10	367	<i>Electrical and Communication Systems</i>	5.5	A
11	368	<i>Engineering Design</i>	1.4	
12	369	<i>Fluid and Thermal Systems</i>	4.4	B
13	369	<i>Electrical and Communication Systems</i>	5.1	D
14	369	<i>Engineering Design</i>	1.5	B
15	370	<i>Electrical and Communication Systems</i>	6.1	D
16	370	<i>Fluid and Thermal Systems</i>	3.3	A
17	370	<i>Electrical and Communication Systems</i>	5.4	D
18	370	<i>Electrical and Communication Systems</i>	5.3	C
19	371	<i>Construction and Manufacturing</i>	2.5	B
20	371	<i>Engineering Design</i>	1.1	B
21	372	<i>Engineering Design</i>	1.2	D
22	372	<i>Construction and Manufacturing</i>	7.2	A
23	373	<i>Fluid and Thermal Systems</i>	4.2	
24	374	<i>Electrical and Communication Systems</i>	6.3	C
25	374	<i>Electrical and Communication Systems</i>	5.3	C
26	374	<i>Fluid and Thermal Systems</i>	4.1	C
27	375	<i>Electrical and Communication Systems</i>	6.4	A
28	375	<i>Fluid and Thermal Systems</i>	3.5	A
29	375	<i>Electrical and Communication Systems</i>	5.2	B
30	376	<i>Fluid and Thermal Systems</i>	3.1	A
31	376	<i>Construction and Manufacturing</i>	2.3	B
32	376	<i>Electrical and Communication Systems</i>	5.2	C
33	377	<i>Fluid and Thermal Systems</i>	3.2	
34	378	<i>Electrical and Communication Systems</i>	6.4	D
35	378	<i>Construction and Manufacturing</i>	2.4	D
36	379	<i>Electrical and Communication Systems</i>	6.2	B
37	379	<i>Engineering Design</i>	1.2	C
38	379	<i>Electrical and Communication Systems</i>	6.1	A
39	379	<i>Fluid and Thermal Systems</i>	4.4	D
40	380	<i>Engineering Design</i>	1.5	D
41	381	<i>Construction and Manufacturing</i>	2.1	A

Item No.	Page No.	Reporting Category	Standard	Correct Answer (MC)*
42	381	<i>Engineering Design</i>	1.4	C
43	381	<i>Fluid and Thermal Systems</i>	4.2	A
44	382	<i>Construction and Manufacturing</i>	2.6	
45	383	<i>Electrical and Communication Systems</i>	6.5	

* Answers are provided here for multiple-choice items only. Sample responses and scoring guidelines for open-response items, which are indicated by shaded cells, will be posted to the Department's website later this year.