XII. Mathematics, Grade 6

Grade 6 Mathematics Test

The spring 2013 grade 6 Mathematics test was based on standards in the five domains for grade 6 in the Massachusetts *Curriculum Framework for Mathematics* (March 2011). The grade 6 standards can be found on pages 53–58 in the *Framework*, and the five domains are listed below.

- Ratios and Proportional Relationships
- The Number System
- Expressions and Equations
- Geometry
- Statistics and Probability

The *Curriculum Framework for Mathematics* is available on the Department website at www.doe.mass.edu/frameworks/current.html.

Mathematics test results are reported under five MCAS reporting categories, which are identical to the five framework domains listed above.

Test Sessions

The grade 6 Mathematics test included two separate test sessions. Each session included multiple-choice, short-answer, and open-response questions. Approximately half of the common test items are shown on the following pages as they appeared in test booklets.

Reference Materials and Tools

Each student taking the grade 6 Mathematics test was provided with a plastic ruler and a grade 6 Mathematics Reference Sheet. A copy of the reference sheet follows the final question in this chapter. An image of the ruler is not reproduced in this publication.

The use of bilingual word-to-word dictionaries was allowed for current and former English language learner students only, during both Mathematics test sessions. No calculators, other reference tools, or materials were allowed.

Cross-Reference Information

The tables at the conclusion of this chapter indicate each released and unreleased common item's reporting category and the framework standard it assesses. The correct answers for released multiple-choice and short-answer questions are also displayed in the released item table.

Grade 6 Mathematics

SESSION 1

You may use your reference sheet and MCAS ruler during this session.
You may **not** use a calculator during this session.



DIRECTIONS

This session contains eight multiple-choice questions, two short-answer questions, and one open-response question. Mark your answers to these questions in the spaces provided in your Student Answer Booklet.

- 1 There are 10^9 nanoseconds in one second. Which of the following is equivalent to 10^9 ?
- A. one hundred million
 - B. one million
 - C. ten billion
 - D. one billion

- 2 Alice and Carl each have the same total number of marbles.
- Alice put her marbles into groups of 4 with none left over.
 - Carl put his marbles into groups of 10 with none left over.

What is the **least** total number of marbles that Alice and Carl can each have?

- A. 16
- B. 20
- C. 32
- D. 40

- 3 At a grocery store, one pound of grapes costs \$2.25. In the following expressions, p represents any number of pounds of grapes.

Which expression represents the cost, in dollars, of p pounds of grapes?

- A. $p - 2.25$
- B. $2.25 + p$
- C. $p \div 2.25$
- D. $2.25 \times p$

- 4 Ming is making cookies. To make 30 cookies, his recipe requires 3 eggs. Using this recipe, what is the total number of eggs he will need to make 120 cookies?

- A. 6
- B. 9
- C. 10
- D. 12

- 5 The net of a triangular prism and its dimensions are shown below.

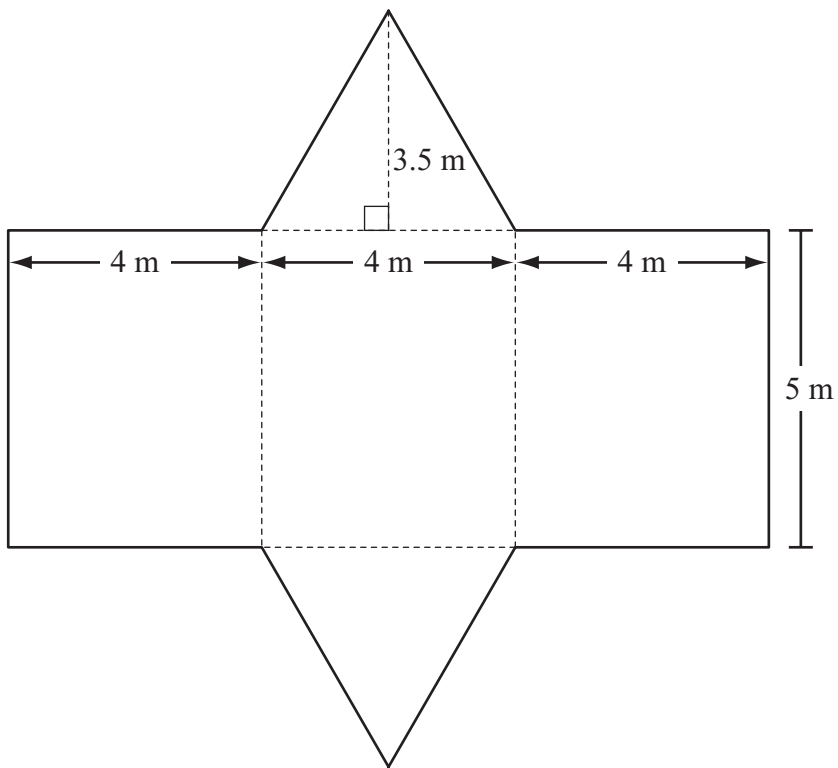

What is the total surface area of the prism?

- A. 54 m^2
- B. 60 m^2
- C. 74 m^2
- D. 76 m^2

Questions 6 and 7 are short-answer questions. Write your answers to these questions in the boxes provided in your Student Answer Booklet. Do not write your answers in this test booklet. You may do your figuring in the test booklet.

- 6 The location of point K is shown on the number line below.

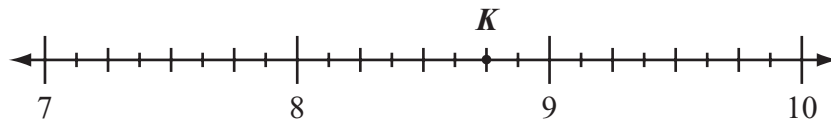

What mixed number is represented by the location of point K ?

- 7 Last week Colby baby-sat for 12 hours and earned \$156. He earned the same amount of money for each hour he baby-sat.

How much money, in dollars, did Colby earn per hour for baby-sitting?

Mark your answers to multiple-choice questions 8 through 10 in the spaces provided in your Student Answer Booklet. Do not write your answers in this test booklet. You may do your figuring in the test booklet.

- 8 Paula plotted $\triangle PQR$, point S , and point T , as shown on the coordinate plane below.

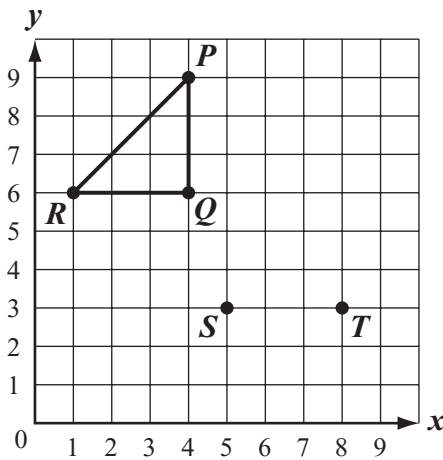

Paula wants to plot point U so that point S , point T , and point U are the vertices of a triangle that is the same size and shape as $\triangle PQR$.

Which of the following **cannot** be the coordinates of point U ?

- A. (4, 0)
- B. (5, 6)
- C. (8, 0)
- D. (8, 6)

- 9 Dwayne answered 80% of the questions on a quiz correctly. If he answered 40 questions correctly, what was the total number of questions on Dwayne's quiz?

- A. 32
- B. 50
- C. 60
- D. 120

- 10 Jacob is making a kite that has the dimensions shown below.

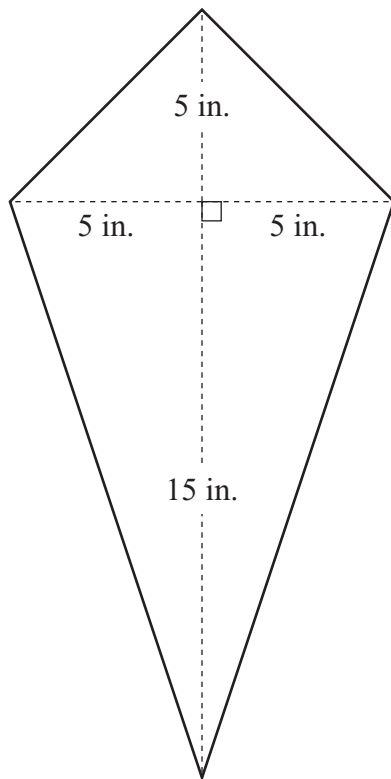

What is the area of Jacob's kite?

- A. 25 sq. in.
- B. 50 sq. in.
- C. 100 sq. in.
- D. 200 sq. in.

Question 11 is an open-response question.

- **BE SURE TO ANSWER AND LABEL ALL PARTS OF THE QUESTION.**
- **Show all your work (diagrams, tables, or computations) in your Student Answer Booklet.**
- **If you do the work in your head, explain in writing how you did the work.**

Write your answer to question 11 in the space provided in your Student Answer Booklet.

- 11** A salesperson records the number of miles she travels each week. The table below shows the number of miles the salesperson traveled each week for 5 weeks.

Weekly Travel

Week	1	2	3	4	5
Number of Miles Traveled	216	210	250	225	209

- a. What is the median number of miles traveled by the salesperson? Show or explain how you got your answer.
- b. What is the mean number of miles traveled by the salesperson? Show or explain how you got your answer.

The salesperson plans to travel 402 miles in week 6.

- c. Which measure, median or mean, will change more when the number of miles for week 6 is included in the data? Show or explain how you got your answer.

Grade 6 Mathematics

SESSION 2

You may use your reference sheet and MCAS ruler during this session.
You may **not** use a calculator during this session.



DIRECTIONS

This session contains eight multiple-choice questions, one short-answer question, and one open-response question. Mark your answers to these questions in the spaces provided in your Student Answer Booklet.

- 12 Which of the following is equivalent to the expression below?

$$2\frac{1}{2} \div \frac{1}{4}$$

- A. $1\frac{3}{5}$
- B. $2\frac{1}{8}$
- C. 4
- D. 10

- 13 Alexia uses 5 cups of water for every 3 cups of rice she cooks. What is the ratio of rice to water?

- A. $\frac{2}{8}$
- B. $\frac{8}{2}$
- C. $\frac{3}{5}$
- D. $\frac{5}{3}$

- 14 Victor drew trapezoid $PQRS$ on a coordinate plane. The coordinates of each vertex are listed below.

- $P(8, 4)$
- $Q(10, 4)$
- $R(13, -1)$
- $S(8, -1)$

What is the length, in units, of side PS ?

- A. 2
- B. 3
- C. 4
- D. 5

- 15 The table below shows the low temperature in a town each day for four days.

Low Temperatures

Day	Monday	Tuesday	Wednesday	Thursday
Temperature (in °F)	5	1	-8	-3

Which of the following lists the temperatures in order from least to greatest?

- A. 1, -3, 5, -8
- B. -3, -8, 1, 5
- C. -8, -3, 5, 1
- D. -8, -3, 1, 5

- 16 Which of the following rules is true for all values in the input-output table below?

Input (x)	Output (y)
2	4
3	6
6	12
8	16
10	20

- A. $x + 1 = y$
B. $x + 2 = y$
C. $2x = y$
D. $3x - 2 = y$

Question 17 is a short-answer question. Write your answer to question 17 in the box provided in your Student Answer Booklet. Do not write your answer in this test booklet. You may do your figuring in the test booklet.

- 17** A circle has a diameter of 20 centimeters. What is the area, in square centimeters, of the circle? (Use 3.14 for π .)

Question 18 is an open-response question.

- **BE SURE TO ANSWER AND LABEL ALL PARTS OF THE QUESTION.**
- **Show all your work (diagrams, tables, or computations) in your Student Answer Booklet.**
- **If you do the work in your head, explain in writing how you did the work.**

Write your answer to question 18 in the space provided in your Student Answer Booklet.

- 18** A table can be used to show the relationship between the number of hours a painter works painting and the total amount the painter charges for painting. In your Student Answer Booklet, copy the table below about the painter’s charges.

Painter’s Charges

Number of Hours (h)	1	2	3	4	5
Total Charge for Painting (c)					

The painter charges \$25 per hour to paint a room.

- a. Complete the table you copied in your Student Answer Booklet to show the relationship between h , the number of hours the painter works, and c , the total amount, in dollars, the painter charges for painting.
- b. Write an equation that can be used to find c , the total charge for h hours of painting.

It took the painter 13 hours to paint a room.

- c. What is the total amount, in dollars, the painter charged for painting the room? Show or explain how you got your answer.

Mark your answers to multiple-choice questions 19 through 21 in the spaces provided in your Student Answer Booklet. Do not write your answers in this test booklet. You may do your figuring in the test booklet.

- 19 What is the value of the expression below when $t = 6$?

$$5t - 2$$

- A. 20
- B. 28
- C. 30
- D. 32

- 20 There is a total of 140 calories in 20 of Mei’s favorite crackers. What is the total number of calories in 300 of Mei’s favorite crackers?

- A. 2100
- B. 2800
- C. 4200
- D. 6000

- 21 Points Q and R on the number line below each represent a real number.

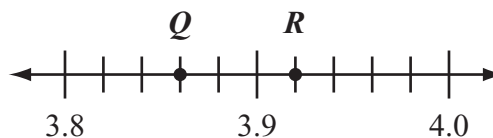

Which of the following numbers is located **between** points Q and R on the number line?

- A. 3.84
- B. 3.88
- C. 3.94
- D. 3.98

PERIMETER FORMULAS

perimeter = distance around

square $P = 4s$

rectangle $P = 2b + 2h$

OR

$P = 2l + 2w$

triangle $P = a + b + c$

AREA FORMULAS

square $A = s \times s$

rectangle $A = bh$

OR

$A = lw$

parallelogram $A = bh$

triangle $A = \frac{1}{2}bh$

circle $A = \pi r^2$

VOLUME FORMULAS

rectangular prism $V = lwh$

cube $V = s \times s \times s$

(s = length of an edge)

CIRCLE FORMULAS

$C = 2\pi r$

OR

$C = \pi d$

$A = \pi r^2$

Grade 6 Mathematics
Spring 2013 Released Items:
Reporting Categories, Standards, and Correct Answers*

Item No.	Page No.	Reporting Category	Standard	Correct Answer (MC/SA)*
1	204	<i>Expressions and Equations</i>	EE.1	D
2	204	<i>The Number System</i>	NS.4	B
3	205	<i>Expressions and Equations</i>	EE.2	D
4	205	<i>Ratios and Proportional Relationships</i>	RP.3	D
5	206	<i>Geometry</i>	G.4	C
6	207	<i>The Number System</i>	NS.6	$8\frac{3}{4}$
7	207	<i>Ratios and Proportional Relationships</i>	RP.2	\$13
8	208	<i>Geometry</i>	G.3	A
9	208	<i>Ratios and Proportional Relationships</i>	RP.3	B
10	209	<i>Geometry</i>	G.1	C
11	210	<i>Statistics and Probability</i>	SP.5	
12	211	<i>The Number System</i>	NS.1	D
13	211	<i>Ratios and Proportional Relationships</i>	RP.2	C
14	211	<i>Geometry</i>	G.3	D
15	212	<i>The Number System</i>	NS.7	D
16	213	<i>Expressions and Equations</i>	EE.9	C
17	214	<i>Geometry</i>	G.1	314 square centimeters
18	215	<i>Expressions and Equations</i>	EE.9	
19	216	<i>Expressions and Equations</i>	EE.2	B
20	216	<i>Ratios and Proportional Relationships</i>	RP.3	A
21	216	<i>The Number System</i>	NS.6	B

* Answers are provided here for multiple-choice and short-answer items only. Sample responses and scoring guidelines for open-response items, which are indicated by the shaded cells, will be posted to the Department's website later this year.

Grade 6 Mathematics
Spring 2013 Unreleased Common Items:
Reporting Categories and Standards

Item No.	Reporting Category	Standard
22	<i>The Number System</i>	NS.6
23	<i>Expressions and Equations</i>	EE.2
24	<i>Statistics and Probability</i>	SP.4
25	<i>Expressions and Equations</i>	EE.7
26	<i>Geometry</i>	G.1
27	<i>The Number System</i>	NS.5
28	<i>Geometry</i>	G.4
29	<i>The Number System</i>	NS.3
30	<i>Expressions and Equations</i>	EE.1
31	<i>Expressions and Equations</i>	EE.9
32	<i>Statistics and Probability</i>	SP.4
33	<i>Expressions and Equations</i>	EE.1
34	<i>Expressions and Equations</i>	EE.7
35	<i>The Number System</i>	NS.4
36	<i>Statistics and Probability</i>	SP.4
37	<i>Geometry</i>	G.2
38	<i>Statistics and Probability</i>	SP.5
39	<i>Expressions and Equations</i>	EE.6
40	<i>The Number System</i>	NS.2
41	<i>Expressions and Equations</i>	EE.9
42	<i>Ratios and Proportional Relationships</i>	RP.3