XVII. Science and Technology/Engineering,
Grade 8

Grade 8 Science and Technology/Engineering Test

The spring 2019 grade 8 Science and Technology/Engineering (STE) test was a next-generation assessment that was administered in two primary formats: a computer-based version and a paper-based version. The vast majority of students took the computer-based test. The paper-based test was offered as an accommodation for students with disabilities who are unable to use a computer, as well as for English learners who are new to the country and are unfamiliar with technology.

Most of the operational items on the grade 8 STE test were the same, regardless of whether a student took the computer-based version or the paper-based version. In places where a technology-enhanced item was used on the computer-based test, an adapted version of the item was created for use on the paper test. These adapted paper items were multiple-choice or multiple-select items that tested the same STE content and assessed the same standard as the technology-enhanced item.

This document displays released items from the paper-based test. Released items from the computer-based test are available on the MCAS Resource Center website at mcas.pearsonsupport.com/released-items.

Test Sessions and Content Overview

The grade 8 STE test was made up of two separate test sessions. Each session included selected-response questions and constructed-response questions. On the paper-based test, the selected-response questions were multiple-choice items and multiple-select items, in which students select the correct answer(s) from among several answer options.

Standards and Reporting Categories

The grade 8 STE test was based on learning standards in the four major content strands in the April 2016 version of the *Massachusetts Science and Technology/Engineering Curriculum Framework*. The four content strands are listed below.

- Earth and Space Science
- Life Science (Biology)
- Physical Sciences (Chemistry and Physics)
- Technology/Engineering

The 2016 *Massachusetts Science and Technology/Engineering Curriculum Framework* is available on the Department website at www.doe.mass.edu/frameworks/current.html.

Science and Technology/Engineering test results are reported under four MCAS reporting categories, which are identical to the four framework content strands listed above.

The tables at the conclusion of this chapter provide the following information about each released and unreleased operational item: reporting category, standard covered, practice category covered (if any), item type, and item description. The correct answers for released selected-response questions are also displayed in the released item table.

Reference Materials

During both STE test sessions, the use of bilingual word-to-word dictionaries was allowed for current and former English learner students.

Grade 8 Science and Technology/Engineering SESSION 1

This session contains 10 questions.

Directions

Read each question carefully and then answer it as well as you can. You must record all answers in this Test & Answer Booklet.

For some questions, you will mark your answers by filling in the circles in your Test & Answer Booklet. Make sure you darken the circles completely. Do not make any marks outside of the circles. If you need to change an answer, be sure to erase your first answer completely.

If a question asks you to show or explain your work, you must do so to receive full credit. Write your response in the space provided in your Test & Answer Booklet. Only responses written within the provided space will be scored.

The following section focuses on the Golden Gate Bridge.

Read the information below and use it to answer the three selected-response questions and one constructed-response question that follow.

Students in a class are studying the Golden Gate Bridge in San Francisco, California, to learn about how suspension bridges are designed and how different loads affect them. The students recorded the following information.

- Millions of kilograms of concrete and steel were used to construct the bridge.
- When designing the bridge, engineers had to take into consideration natural events, such as earthquakes and strong winds.
- About 40 million cars per year cross the bridge.
- The deck of the bridge includes a sidewalk 3 m wide used by many bicyclists and pedestrians.
- Although the bridge looks horizontally straight, it has a small arc: the deck of the bridge is 26 m higher at its center than it is on either end.
- When the outside temperature changes, the length and shape of the bridge changes.
- The bridge is designed for a live load of 4,000 lb./ft.

The diagram shows the Golden Gate Bridge with some of its structures labeled.

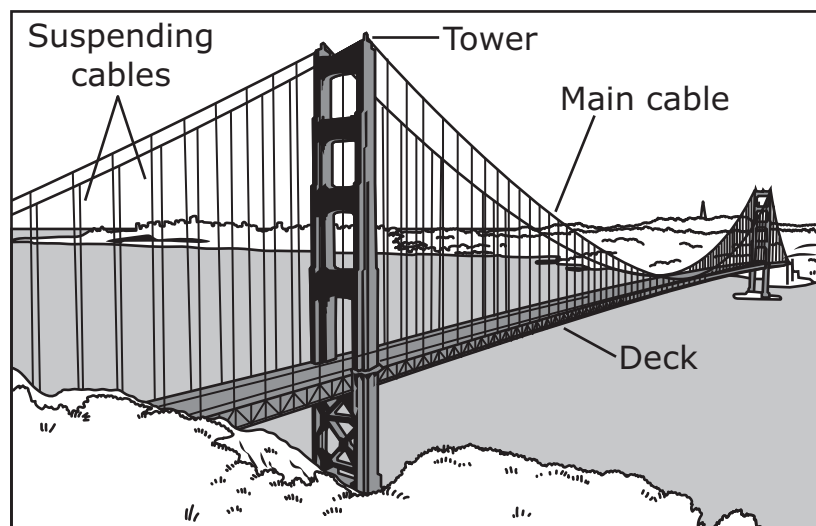

- 1 The arrow in the picture points to a part of the Golden Gate Bridge made of concrete.

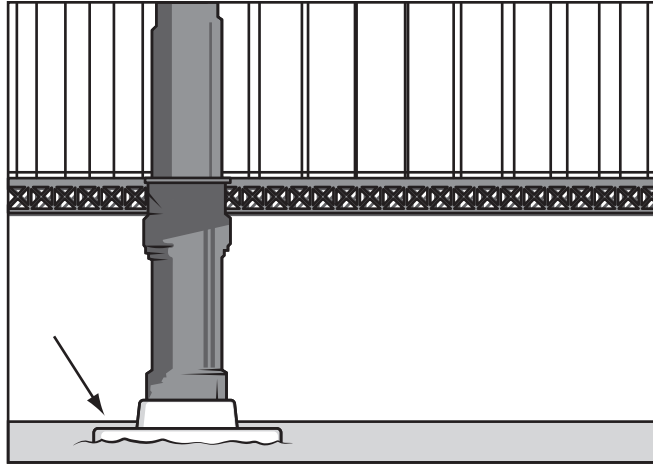

Which of the following best explains why the engineers used concrete to build this part of the bridge?

- (A) Concrete is low in density so this part of the bridge can float on top of the water.
- (B) Concrete is very heavy so this part of the bridge can move back and forth in the wind.
- (C) Concrete is low in density so this part of the bridge can move back and forth in the wind.
- (D) Concrete is high in strength so this part of the bridge can support a large amount of weight.

- 2 A student makes this particle model of atoms that make up part of the bridge. The model shows the atoms when the bridge is at 18°C.



The student wants to make a new model to show the atoms when the bridge is heated to 23°C.

Which of the following changes should the student include in the new model?

- Ⓐ making the atoms bigger
- Ⓑ making the atoms a different shape
- Ⓒ making larger spaces between the atoms
- Ⓓ making chemical bonds between the atoms

- 3 Small earthquakes are relatively common near the Golden Gate Bridge, but major earthquakes occur less often. Major earthquakes only occur when a large amount of energy is carried by seismic waves.

Which of the following must be large for a major earthquake to occur?

- Ⓐ the speed of the seismic waves
- Ⓑ the frequency of the seismic waves
- Ⓒ the amplitude of the seismic waves
- Ⓓ the wavelength of the seismic waves

This question has three parts. Write your response on the next page. Be sure to label each part of your response.

- 4** The students work in teams to create and test models of bridges made of straws and tape. The bridges are built between two tables, which are not considered part of the bridge. The diagram shows a bridge created by one of the teams.

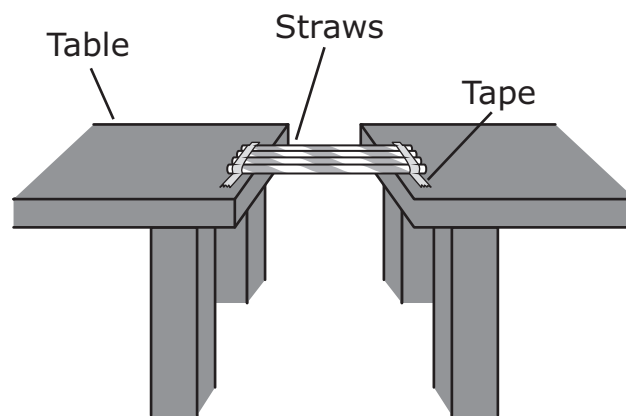

The team tests the strength of the bridge by adding coins, one at a time, to the deck of the bridge. The team records how many coins the bridge can support before it collapses.

- A. Identify what the coins most likely represent in this test.
- B. Identify **all** the materials that are a part of the total load of the bridge when the team tests the strength of the bridge.

The team then adds more straws and tape and tests the strength of the bridge again.

- C. Describe one advantage **and** one disadvantage of adding more materials.

This question has three parts. Write your response on the next page. Be sure to label each part of your response.

- 5** The diagram shows two oceanic plates, plate W and plate X. The plates are moving toward each other, with plate X being pushed under plate W.

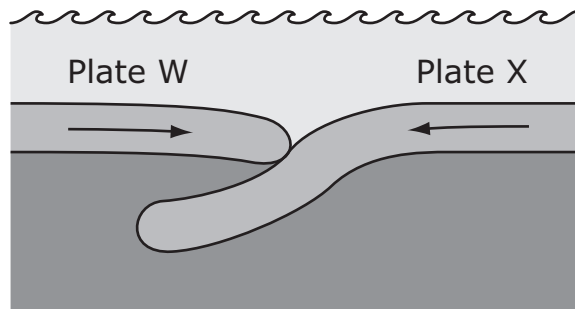

- Identify one geological feature that will form as plate X is pushed under plate W.
- Describe what happens to the solid material of plate X when it is pushed beneath plate W. Explain why this happens.
- Describe the process that causes the plates to move toward each other. In your answer, be sure to identify the layer of Earth where this process occurs.

5

Lined writing area with 20 horizontal lines.

- 6 Two pea plants are crossed. Each parent plant has a dominant allele for height (**H**) and a recessive allele for height (**h**).

Which of the following shows the expected percentage of each genotype for the offspring of these parents?

Ⓐ

Genotype	Percentage
HH	0%
Hh	100%
hh	0%

Ⓑ

Genotype	Percentage
HH	25%
Hh	50%
hh	25%

Ⓒ

Genotype	Percentage
HH	50%
Hh	50%
hh	0%

Ⓓ

Genotype	Percentage
HH	0%
Hh	50%
hh	50%

7 A large puddle forms in a low area of a park every time it rains. Visitors to the park complain about the puddle. A landscaper is considering two design solutions to solve the problem:

- Solution 1: adding dirt to build up the low area so rainwater becomes runoff instead of a puddle
- Solution 2: creating a rain garden so rainwater becomes groundwater instead of a puddle

The diagrams show an example of each solution.

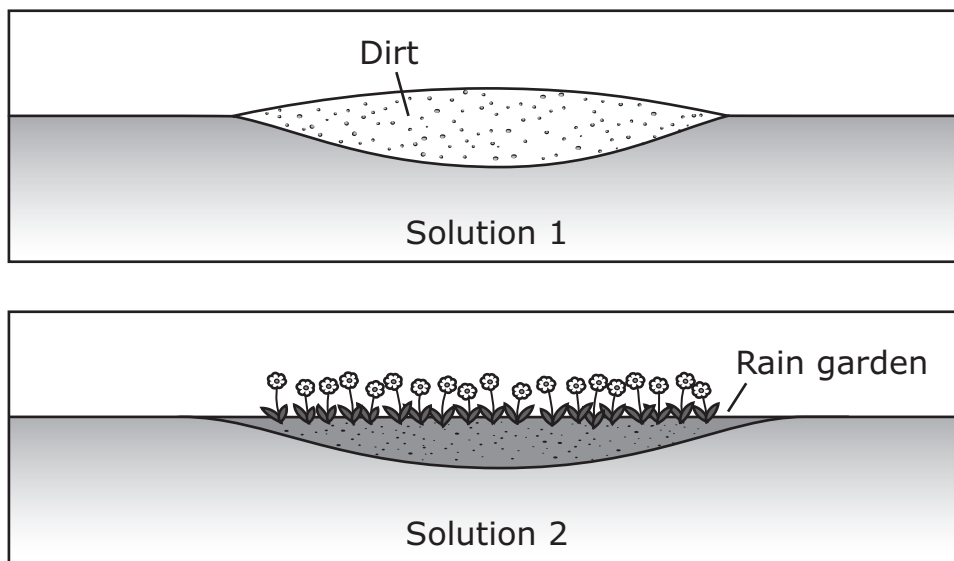

Which of the following is the main advantage of solution 2 compared to solution 1?

- Ⓐ The rain garden would take less time to make.
- Ⓑ The rain garden would be less expensive to maintain.
- Ⓒ The rain garden would help prevent erosion of the area.
- Ⓓ The rain garden would move more water across the ground.

This question has two parts.

- 8** An artist made a model airplane out of solid wood. The artist began by making the body of the airplane, the wings, and other parts. Then the artist put the parts together to make the finished product.

Part A

Which of the following best describes a separation process the artist used to create the desired shape for the body of the airplane?

- Ⓐ removing pieces from a block of wood
- Ⓑ gluing the different wooden parts together
- Ⓒ using heat to change the properties of the wood
- Ⓓ sorting the different wooden parts into categories

Part B

Which of the following is a finishing process?

- Ⓐ placing the airplane in a display
- Ⓑ painting the body of the airplane
- Ⓒ making sure the airplane is to scale
- Ⓓ attaching the airplane's wings to the body

- 9 The diagrams represent the movement of particles in two samples of the same gas. The samples are in identical, closed, glass containers. The length of an arrow represents the speed of a gas particle.

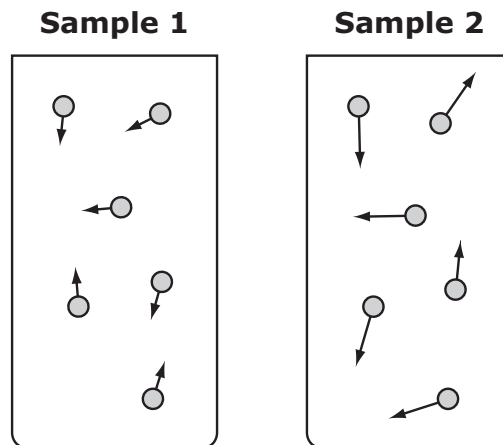

Which of the following **must** be different between the two samples?

- Ⓐ color
- Ⓑ mass
- Ⓒ temperature
- Ⓓ volume

- 10 A student measured three objects made of different materials. The table shows each object's mass and volume.

Object	Mass (g)	Volume (cm ³)
block of wood	250	580
large glass marble	50	21
rubber ball	500	540

Which of the following lists the materials in order from least dense to most dense?

- Ⓐ glass → wood → rubber
- Ⓑ glass → rubber → wood
- Ⓒ rubber → glass → wood
- Ⓓ wood → rubber → glass

Grade 8

Science and Technology/Engineering

SESSION 2

This session contains 10 questions.

Directions

Read each question carefully and then answer it as well as you can. You must record all answers in this Test & Answer Booklet.

For some questions, you will mark your answers by filling in the circles in your Test & Answer Booklet. Make sure you darken the circles completely. Do not make any marks outside of the circles. If you need to change an answer, be sure to erase your first answer completely.

If a question asks you to show or explain your work, you must do so to receive full credit. Write your response in the space provided in your Test & Answer Booklet. Only responses written within the provided space will be scored.

- 11 The model shows Earth at two different positions during its orbit around the Sun.

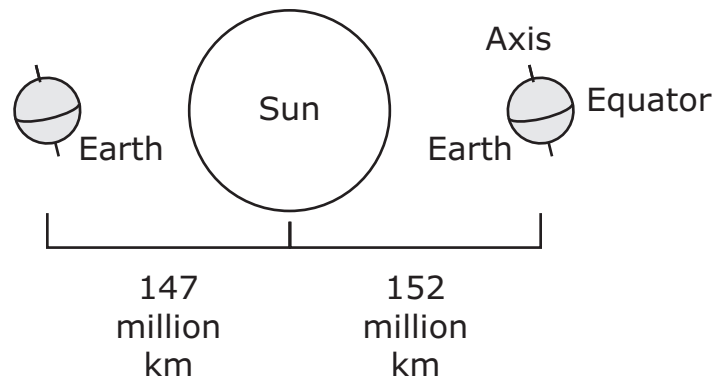

Which of the following explains why seasons change in Massachusetts as Earth travels around the Sun?

- Ⓐ Earth's tilted axis causes uneven heating of Earth's surface by the Sun.
- Ⓑ Earth's tilted axis causes the Sun to appear larger in the sky from Earth.
- Ⓒ Earth's orbital distance causes uneven heating of Earth's surface by the Sun.
- Ⓓ Earth's orbital distance causes the distance between Earth and the Sun to change.

- 12 Four objects labeled W, X, Y, and Z have different forces applied to them. All of the horizontal forces acting on each object are shown in the diagrams.

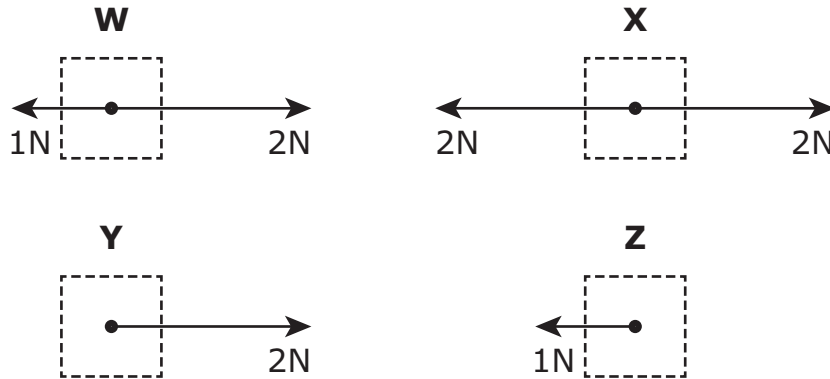

Which table correctly classifies the four objects according to whether the speeds of the objects are changing?

(A)

Speed Changing	Speed Not Changing
objects Y and Z	objects W and X

(B)

Speed Changing	Speed Not Changing
objects W and X	objects Y and Z

(C)

Speed Changing	Speed Not Changing
objects W, Y, and Z	object X

(D)

Speed Changing	Speed Not Changing
object X	objects W, Y, and Z

- 13 Polar bears live in the Northern Hemisphere and need a large amount of Arctic ice to hunt. Which of the following is **most likely** to occur if the amount of Arctic ice in polar regions decreases significantly over a short period of time?
- Ⓐ Polar bears will migrate south.
 - Ⓑ Polar bears will become extinct.
 - Ⓒ Polar bears will develop a larger body size.
 - Ⓓ Polar bears will adapt to water environments.

- 14 The model shows water cycling through Earth’s systems. The water cycle is affected by energy from the Sun and by the force of gravity.

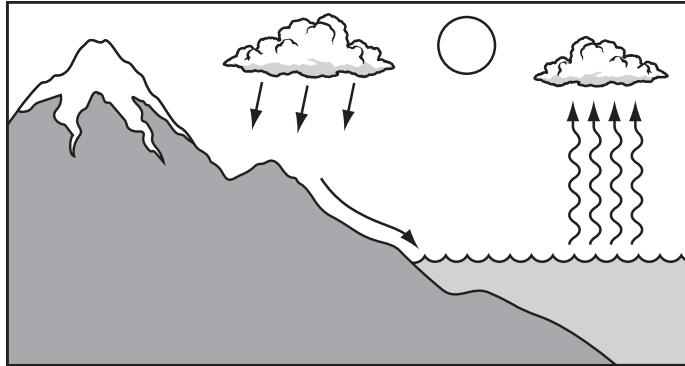

Which of the following best shows the ways that energy from the Sun and the force of gravity affect the cycling of water?

- (A)
- | Energy from the Sun | Force of Gravity |
|---|---|
| <ul style="list-style-type: none"> • evaporation of water • melting of snow and ice | <ul style="list-style-type: none"> • surface runoff • precipitation |
- (B)
- | Energy from the Sun | Force of Gravity |
|---|---|
| <ul style="list-style-type: none"> • evaporation of water • precipitation | <ul style="list-style-type: none"> • melting of snow and ice • surface runoff |
- (C)
- | Energy from the Sun | Force of Gravity |
|---|---|
| <ul style="list-style-type: none"> • surface runoff • precipitation | <ul style="list-style-type: none"> • evaporation of water • melting of snow and ice |
- (D)
- | Energy from the Sun | Force of Gravity |
|---|---|
| <ul style="list-style-type: none"> • melting of snow and ice • surface runoff | <ul style="list-style-type: none"> • precipitation • evaporation of water |

- 15 Several objects are located on a set of shelves in a classroom. The mass of each object is given in the table, and the diagram shows the location of each object on the set of shelves.

Object	Mass (kg)
bowl	0.40
school supply box	0.95
rubber ball	0.55
lunchbox	1.10

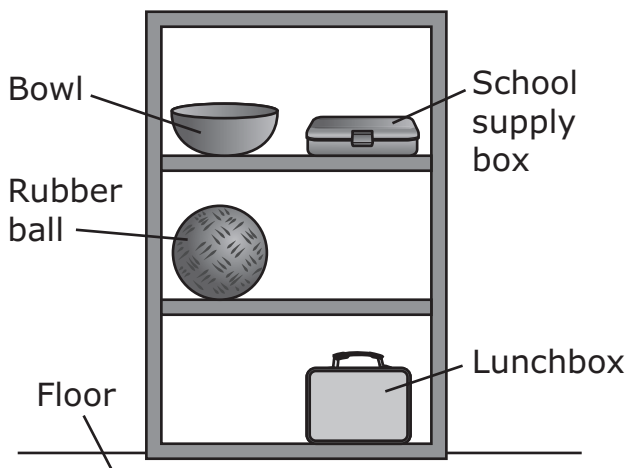

Which object has the largest potential energy relative to the floor?

- Ⓐ bowl
- Ⓑ lunchbox
- Ⓒ rubber ball
- Ⓓ school supply box

This question has two parts. Write your response below. Be sure to label each part of your response.

16 Many traits of horses, such as coat color, are artificially selected when horses are bred.

A. Describe one advantage of selecting traits artificially in horses.

B. Describe one disadvantage of selecting traits artificially in horses.

16

- 17 Hawks and owls are both birds of prey and often live in the same areas. Which of the following factors **most likely** limits competition for prey between hawks and owls living in the same area?
- Ⓐ Hawks and owls have different predators.
 - Ⓑ Hawks have speckled eggs and owls have white eggs.
 - Ⓒ Hawks and owls are camouflaged by different feather colors.
 - Ⓓ Hawks are active during the day and owls are active during the night.

- 18 Some parts of a plant cell are labeled in the diagram shown.

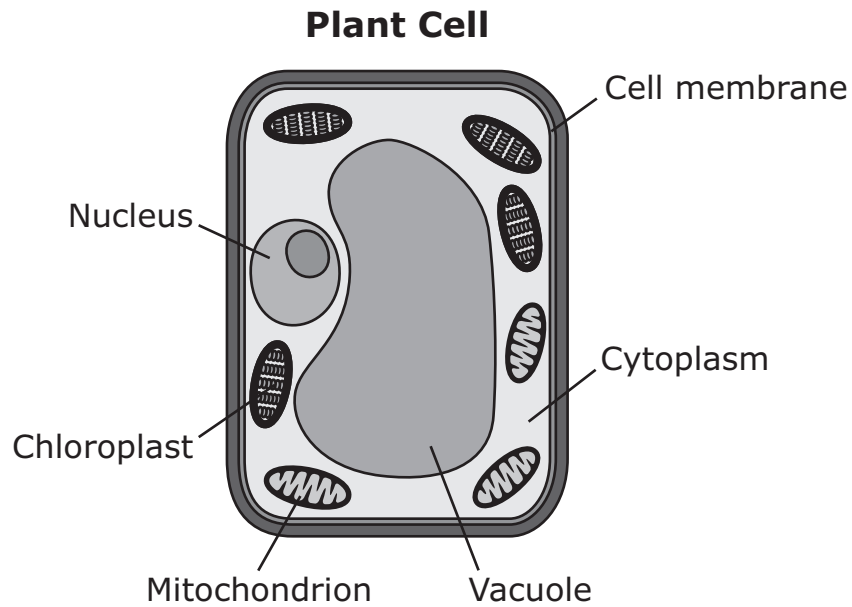

Which part of the plant cell is responsible for producing sugars?

- Ⓐ cell membrane
- Ⓑ chloroplast
- Ⓒ cytoplasm
- Ⓓ mitochondrion
- Ⓔ nucleus
- Ⓕ vacuole

- 19 Which of the following is the **best** example of heat being transferred by conduction?
- Ⓐ ocean currents moving warm water to cold water
 - Ⓑ mountain boulders warming up in bright sunlight
 - Ⓒ rocks buried in sand absorbing heat from surrounding sand
 - Ⓓ air masses moving from high-pressure to low-pressure regions
- 20 Which of the following statements **best** explains why air on Earth circulates between the equator and the poles?
- Ⓐ The atmosphere is higher near the equator than at the poles.
 - Ⓑ The atmosphere is more dense near the equator than at the poles.
 - Ⓒ Earth's gravitational pull is weaker near the equator than at the poles.
 - Ⓓ Earth's surface temperature is greater near the equator than at the poles.

Grade 8 Science and Technology/Engineering
Spring 2019 Released Operational Items

PBT Item No.	Page No.	Reporting Category	Standard	Practice Category	Item Type*	Item Description	Correct Answer**
1	438	<i>Technology/Engineering</i>	6.ETS.2.1	None	SR	Describe why a material is an appropriate choice for part of a bridge.	D
2	439	<i>Physical Sciences</i>	8.PS.1.4	C. Evidence, Reasoning, and Modeling	SR	Describe a change to a particle model that will show the atoms with more thermal energy.	C
3	440	<i>Physical Sciences</i>	6.PS.4.1	None	SR	Relate the amount of energy in a seismic wave to the wave's amplitude.	C
4	441	<i>Technology/Engineering</i>	7.ETS.3.4	C. Evidence, Reasoning, and Modeling	CR	Analyze a model bridge to determine the loads on the system and describe an advantage and a disadvantage of making a design change.	
5	443	<i>Earth and Space Science</i>	8.ESS.2.1	C. Evidence, Reasoning, and Modeling	CR	Interpret a model of two oceanic plates colliding, identify a geological feature that is formed, and describe the process that causes plates to move.	
6	445	<i>Life Science</i>	8.LS.3.4	B. Mathematics and Data	SR	Determine the percentages of genotypes for a cross between two plants that are heterozygous for a particular trait.	B
7	446	<i>Technology/Engineering</i>	7.ETS.1.2	C. Evidence, Reasoning, and Modeling	SR	Evaluate two design solutions to determine an advantage of one solution over the other.	C
8	447	<i>Technology/Engineering</i>	8.ETS.2.5	None	SR	Describe the separation process for creating the desired shape of an object and describe the finishing process for that object.	A;B
9	448	<i>Physical Sciences</i>	7.PS.3.4	C. Evidence, Reasoning, and Modeling	SR	Analyze particle models of two gas samples and determine that the samples differ in temperature.	C
10	449	<i>Physical Sciences</i>	6.PS.1.7	B. Mathematics and Data	SR	Determine the order of a set of objects from least to most dense given the mass and volume of the objects.	D
11	451	<i>Earth and Space Science</i>	8.ESS.1.1	C. Evidence, Reasoning, and Modeling	SR	Interpret a model of the Sun-Earth system to explain the cause of the cyclical pattern of the seasons.	A
12	452	<i>Physical Sciences</i>	8.PS.2.2	C. Evidence, Reasoning, and Modeling	SR	Analyze force models to determine whether the speeds of objects are changing.	C
13	453	<i>Life Science</i>	7.LS.2.4	None	SR	Describe how a change in the amount of Arctic ice in polar regions is most likely to affect a species that lives in these regions.	B
14	454	<i>Earth and Space Science</i>	7.ESS.2.4	C. Evidence, Reasoning, and Modeling	SR	Determine how energy from the Sun and Earth's gravity affect the cycling of water based on a model.	A
15	455	<i>Physical Sciences</i>	7.PS.3.2	B. Mathematics and Data	SR	Determine which object has the largest potential energy based on the mass and relative position of the objects.	D
16	456	<i>Life Science</i>	8.LS.4.5	None	CR	Describe one advantage and one disadvantage of selecting traits artificially in a species.	
17	457	<i>Life Science</i>	7.LS.2.2	C. Evidence, Reasoning, and Modeling	SR	Identify a factor that can limit competition between different species living in the same area.	D
18	458	<i>Life Science</i>	6.LS.1.2	C. Evidence, Reasoning, and Modeling	SR	Use a model to determine the part of a plant cell that produces sugars.	B
19	459	<i>Physical Sciences</i>	7.PS.3.6	None	SR	Identify an example of heat being transferred by conduction.	C
20	459	<i>Earth and Space Science</i>	8.ESS.2.5	None	SR	Determine why air on Earth circulates between the equator and the poles.	D

* Science and Technology/Engineering item types are: selected-response (SR) and constructed-response (CR).

** Answers are provided here for selected-response items only. Sample responses and scoring guidelines for constructed-response items will be posted to the Department's website later this year.

**Grade 8 Science and Technology/Engineering
Spring 2019 Unreleased Operational Items**

PBT Item No.	Reporting Category	Standard	Practice Category	Item Type*	Item Description
21	<i>Earth and Space Science</i>	6.ESS.1.5	C. Evidence, Reasoning, and Modeling	SR	Determine the size of the Sun relative to the planets in our solar system.
22	<i>Technology/Engineering</i>	6.ETS.2.3	A. Investigations and Questioning	SR	Select the appropriate safety equipment and tools needed to construct a prototype.
23	<i>Physical Sciences</i>	7.PS.2.3	B. Mathematics and Data	SR	Compare the strengths of the electric forces between pairs of charges.
24	<i>Life Science</i>	6.LS.1.3	None	SR	Determine the body system that directly controls when muscles contract.
25	<i>Technology/Engineering</i>	7.ETS.3.3	C. Evidence, Reasoning, and Modeling	SR	Determine whether parts of a vehicle are structural, propulsion, or control subsystems.
26	<i>Physical Sciences</i>	6.PS.1.8	A. Investigations and Questioning	SR	Determine the next step in a procedure for separating a mixture, and identify evidence that shows a substance is a mixture.
27	<i>Earth and Space Science</i>	8.ESS.1.2	C. Evidence, Reasoning, and Modeling	CR	Determine which model shows the force that keeps a planet in orbit around a star, and identify that force.
28	<i>Technology/Engineering</i>	7.ETS.3.5	None	SR	Classify part of a transportation system according to the universal systems model.
29	<i>Earth and Space Science</i>	6.ESS.1.4	C. Evidence, Reasoning, and Modeling	SR	Analyze a diagram to determine the youngest rock layer that was present when a fault formed.
30	<i>Earth and Space Science</i>	8.ESS.3.5	B. Mathematics and Data	SR	Analyze a graph to determine a result of changes in atmospheric carbon dioxide levels over time.
31	<i>Life Science</i>	8.LS.1.5	C. Evidence, Reasoning, and Modeling	SR	Determine that genetic differences in individuals of the same species result in different traits.
32	<i>Life Science</i>	7.LS.2.2	C. Evidence, Reasoning, and Modeling	SR	Determine the relationship between a plant and an insect and describe that relationship.
33	<i>Life Science</i>	7.LS.1.4	C. Evidence, Reasoning, and Modeling	SR	Describe how attracting insects can increase the probability of a plant reproducing.
34	<i>Life Science</i>	8.LS.3.2	None	SR	Determine an advantage of a plant reproducing sexually and an advantage of a plant reproducing asexually.
35	<i>Life Science</i>	6.LS.4.1	B. Mathematics and Data	CR	Analyze fossil record data to describe fossils found in different time periods, and describe evidence that could show a relationship between certain plants and insects.
36	<i>Earth and Space Science</i>	7.ESS.2.2	C. Evidence, Reasoning, and Modeling	SR	Determine that an area in New England was once covered by glaciers based on a description of the area.
37	<i>Physical Sciences</i>	6.PS.1.6	A. Investigations and Questioning	CR	Analyze the results of an investigation to determine whether a reaction was endothermic or exothermic, and show how the results should be organized in a lab notebook.
38	<i>Earth and Space Science</i>	6.ESS.1.1	None	SR	Determine the cause of the Moon's phases, and identify what occurs during one cycle of the Moon's phases.
39	<i>Technology/Engineering</i>	6.ETS.2.1	C. Evidence, Reasoning, and Modeling	SR	Identify an important property of a material for a given design task.
40	<i>Technology/Engineering</i>	6.ETS.1.5	B. Mathematics and Data	SR	Use an appropriate ruler to determine the scale of a drawing.
41	<i>Technology/Engineering</i>	7.ETS.3.1	None	SR	Determine why part of a communication system is considered a decoder.

* Science and Technology/Engineering item types are: selected-response (SR) and constructed-response (CR).